

## KAM 7 S Einachsschlepper



### Documenten

Getriebegehäuse

Kupplung

Kupplung (Diesel)

Getriebe (Schaltung)

Achse mit differential

Bremsen und rader

Innere schaltungen

Lenksaule und lenkholm

Frase 60 cm mit einstellbarer haube und Festanschluß 69219102

Frase 60 cm mit einstellbarer haube und Quickfit 69219088

Frase 70 cm mit einstellbarer haube und Quickfit 69219059

Frase 70 cm mit einstellbarer haube und Festanschluß 69219065

Quickfit 69212006

Oil bath movement 69229097

Mulchbalken 69229084/69229085/69229086/69229087

Balken 69229068/69229069/69229070/69229071

Mulchbalken 69229068A/69229069A/69229070A/69229071A

Balken "UNIVERSAL" 69229035/69229036

Balken "clip clap" 69229035/69229036/69229021

Mähbalken L0066900

Mulchbalken "COMUNAL" 69229037/69229038

Towed trailer L0018601

KEES VAN DER SPEK  
TUIN EN PARKHOUW

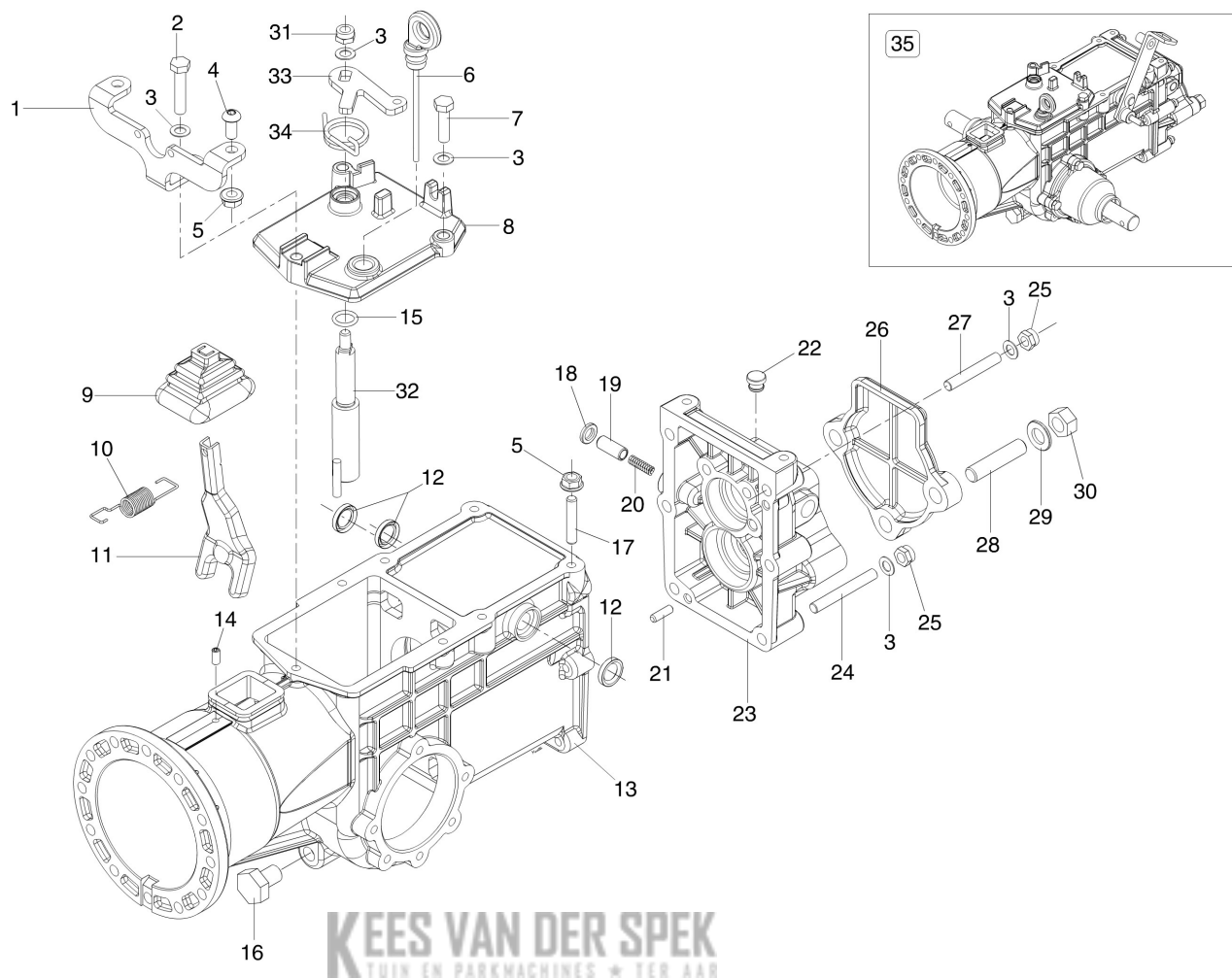

**KEES VAN DER SPEK**  
 TUIN EN PARKMACHINES \* TER AAR

## Illustratie Getriebegehäuse

Bild Nr.	Anz.	Teilenummer	Beschreibung	Gültigkeit ab	Gültigkeit bis	Hinweis	Nachricht
1	1	68350156AR	Halter				
2	1	3806076R	Schraube				
3	18	YN4365400	Scheibe				
4	2	YN6255100	Schraube				
5	6	3933032R	Mutter				
6	1	68350157R	Oelstandsdeckel				
7	3	322000001R	Schraube				
8	1	68350155R	Deckel				
9	1	YF0751646	Balgen				
10	1	68350172AR	Feder				
11	1	YF0750011G	Hebel				
12	3	YN0203000	Kobelring				
13		68350200R	Getriebegehäuse				
14	1	YN6203600	Schraube				
16	1	YN5254000	Oelpfropfen				
17	4	YN3815300	Stiftschraube				
18	1	YN0281400	Ring				
19	1	YF1291661	Kappe				
20	1	YN3101020	Feder				
21	2	YN5124300	Stift				
22	1	3045006	Stopfen				
23	1	YF1290817	Setz deckel				
24	4	YN3825750	Stiftschraube				
25	6	YN1458800	Mutter				
26	1	YF1050833	Deckel				
27	2	YN3825400	Stiftschraube				
28	3	YN3861500	Stiftschraube				
29	3	YN4387700	Scheibe				
30	3	YN1470500	Mutter				
31	1	YN1458800	Mutter				
33	1	68350153R	Hebel				
34	1	YF1291602B	Feder				
15	1	YN0317900	Ring				
32	1	68350090R	Welle				
35	1	68352009BR	Gruppe (Getriebe)				

**KEES VAN DER SPEK**  
TUIN EN PARKMACHINES \* TER AAR

# Illustratie Kupplung

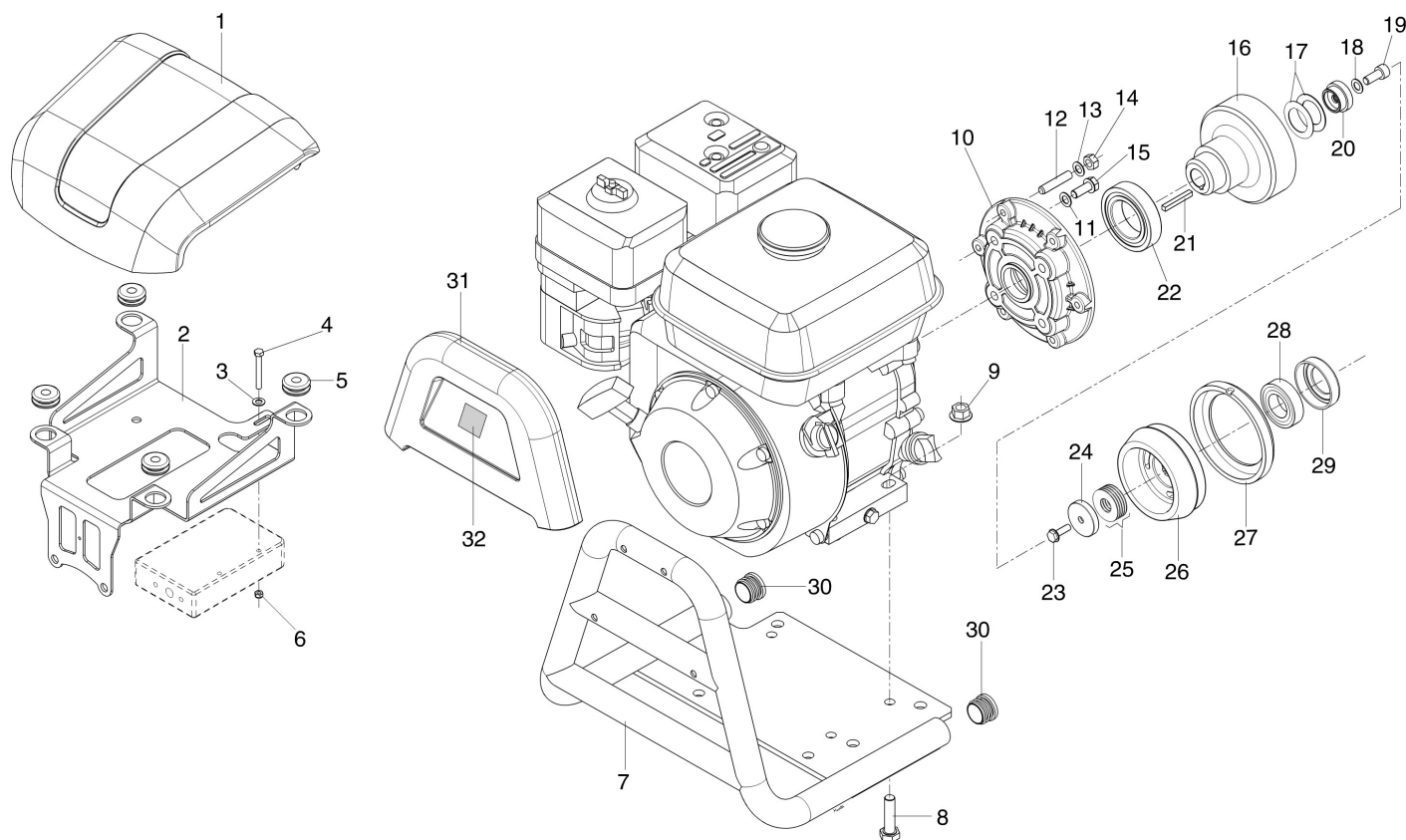

**KEES VAN DER SPEK**  
TUIN EN PARKMACHINES \* TER AAR

## Illustratie Kupplung

Bild Nr.	Anz.	Teilenummer	Beschreibung	Gültigkeit ab	Gültigkeit bis	Hinweis	Nachricht
1	1	68350189R	Haube			Rosso; Red	
2	1	68350065BR	Halter				
3	2	3916006R	Scheibe				
4	2	31000009R	Schraube				
5	4	68350114R	Stütze (Haube)				
6	2	028200069R	Mutter				
7	1	68350164BR	Motorhalterung				
8	4	YN6335900	Schraube				
9	4	3914001R	Mutter				
10	1	68310038AR	Flansch				
11	4	YN6243980	Schraube				
12	6	YN3815300	Stiftschraube				
13	6	YN4365400	Scheibe				
14	6	YN1458020	Mutter				
15	4	YN6243980	Schraube				
16	1	68350073AR	Deckel (Kettenrad)				
17	4	68350212R	Federring				
18	1	YN4365400	Scheibe				
19	1	YN6243950	Schraube				
20	1	68350069R	Buchse				
21	1	YN0643450	Keil				
22	1	N1289300	Lager				
23	1	3906037R	Schraube				
24	1	68350068AR	Buchse				
25	10	68350035AR	Federring				
26	1	68350215R	Kupplung kegel				
27	1	68320137AR	Ring				
28	1	N1270400	Lager				
29	1	68350076R	Deckel				
30	2	YN5267400	Stopfen				
31	1	68350137R	Deckung			Rosso; Red	
32	1	68250018R	Schild NIBBI			Logo "Nibbi"	

**KEES VAN DER SPEK**  
TUIN EN PARKMACHINES • TER AAR

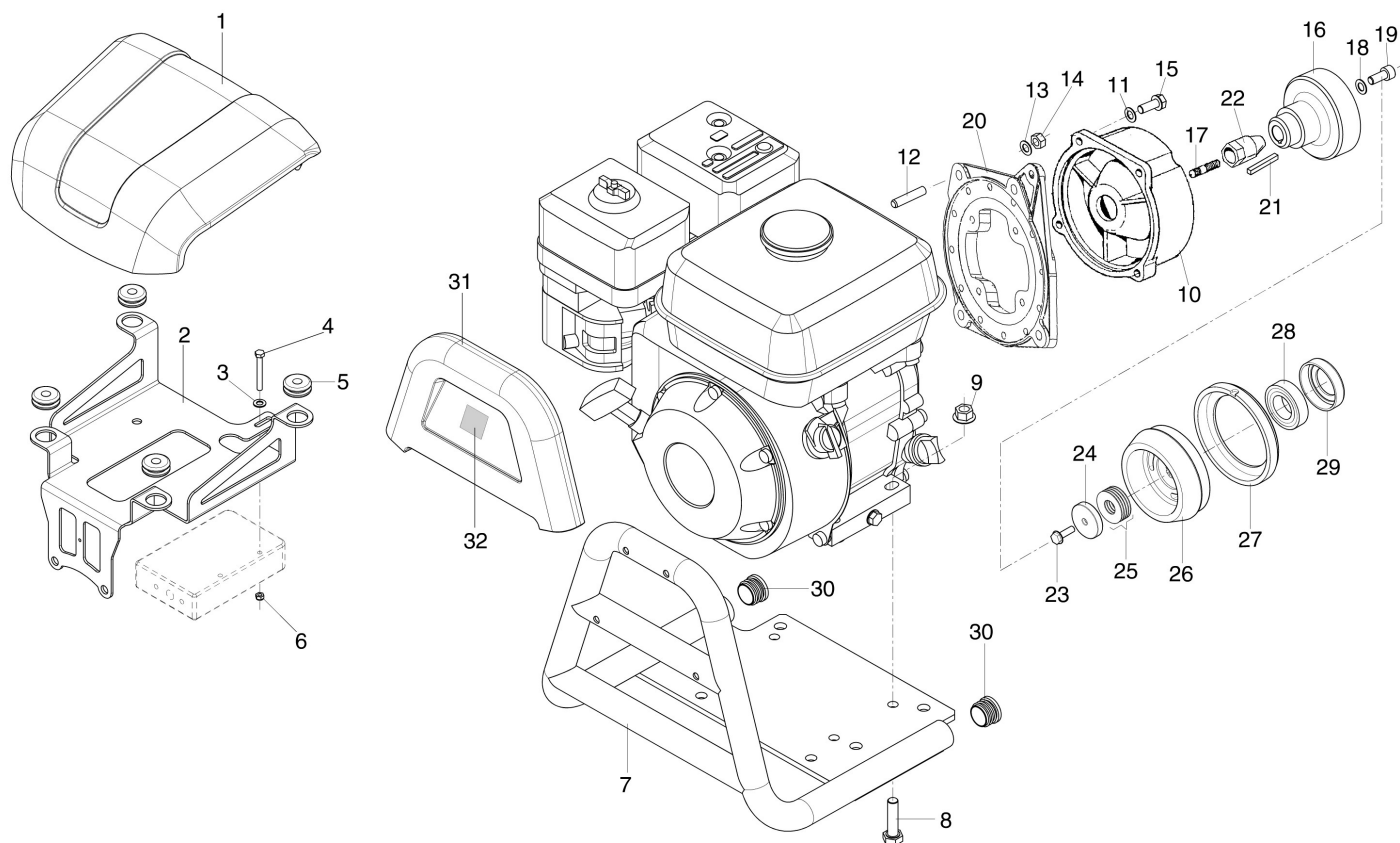

**KEES VAN DER SPEK**  
TUIN EN PARKMACHINES \* TER AAR

## Illustratie Kupplung (Diesel)

Bild Nr.	Anz.	Teilenummer	Beschreibung	Gültigkeit ab	Gültigkeit bis	Hinweis	Nachricht
1	1	68350189R	Haube			Rosso; Red	
2	1	68350065BR	Halter				
3	2	3916006R	Scheibe				
4	2	31000009R	Schraube				
5	4	68350114R	Stütze (Haube)				
6	2	028200069R	Mutter				
7	1	68350170R	Motorhalterung				
8	4	YN6335900	Schraube				
9	4	3914001R	Mutter				
10	1	68320117AR	Flansch				
11	4	YN6243980	Schraube				
12	6	YN3815300	Stiftschraube				
13	6	YN4365400	Scheibe				
14	6	YN1458020	Mutter				
15	4	3906074R	Schraube				
16	1	68350159AR	Deckel (Kettenrad)				
17	4	68350212R	Federring				
18	1	YN4371100	Unterlegscheibe				
19	1	YN6262200	Schraube				
20	1	68320161R	Flansch			Solo per motori KIPOR	
21	1	YN3815300	Stiftschraube				
22	1	YF1290007B	Kupplung kegel				
23	1	3906037R	Schraube				
24	1	68350068AR	Buchse				
25	10	68350035AR	Federring				
26	1	68350215R	Kupplung kegel				
27	1	68320137AR	Ring				
28	1	N1270400	Lager				
29	1	68350076R	Deckel				
30	2	YN5267400	Stopfen				
31	1	68350137R	Deckung			Rosso; Red	
32	1	68250018R	Schild NIBBI			Logo "Nibbi"	

**KEES VAN DER SPEK**  
TUIN EN PARKMACHINES \* TER AAR

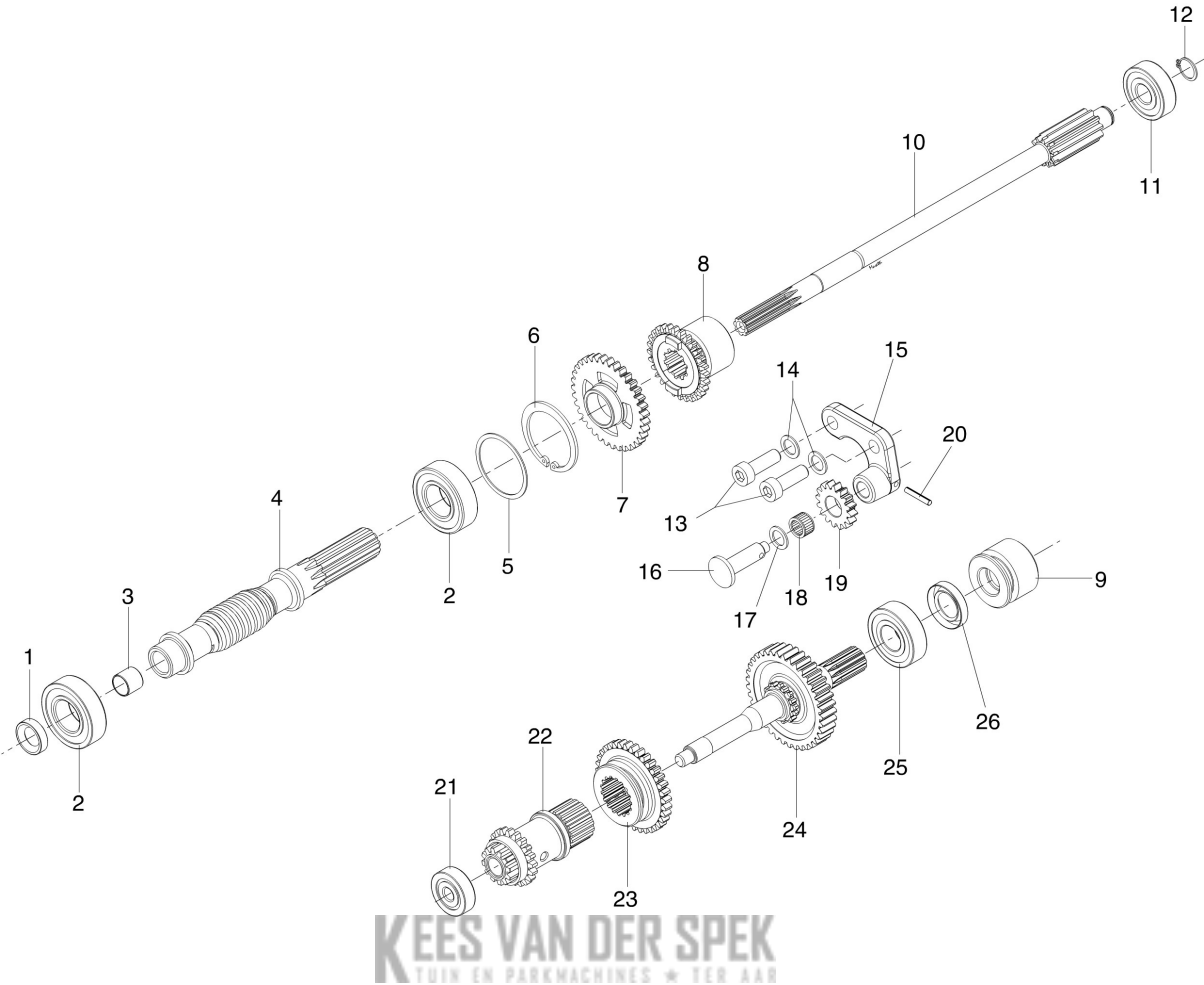

**KEES VAN DER SPEK**  
TUIN EN PARKMACHINES \* TER AAR

## Illustratie Getriebe (Schaltung)

Bild Nr.	Anz.	Teilenummer	Beschreibung	Gültigkeit ab	Gültigkeit bis	Hinweis	Nachricht
1	1	YN0204750	Dichtung				
2	2	YN1270751	Lager				
3	1	3038002R	Buchse				
4	1	68350070R	Welle				
5	1	YN5010200	Scheibe				
6	1	YN0136900	Seeger-ring				
7	1	YF1290812	Zwischenrad				
8	1	68350079AR	Zahnrad (Gleitend)				
9	1	YF1290816A	Kappe				
10	1	68350072AR	Welle				
11	1	YN1257700	Lager				
12	1	3024015R	Seeger-ring				
13	2	YN6330100	Schraube				
14	2	005000343R	Unterlegscheibe				
15	1	YF1290807	Halter				
16	1	68350174R	Stift				
17	1	3064001R	Scheibe				
18	1	3037026R	Rollenkaefig				
19	1	YF1290804	Ritzel				
20	1	YN5115000	Elastiksplint				
21	1	YN1251500	Lager				
22	1	68350077AR	Doppelzahnrad				
23	1	YF1290805	Ritzel				
24	1	R1290814	Welle (Komplet)				
25	1	YN1263701	Lager				
26	1	YN0207300	Kobelring				

**KEES VAN DER SPEK**  
TUIN EN PARKMACHINES \* TER AAR

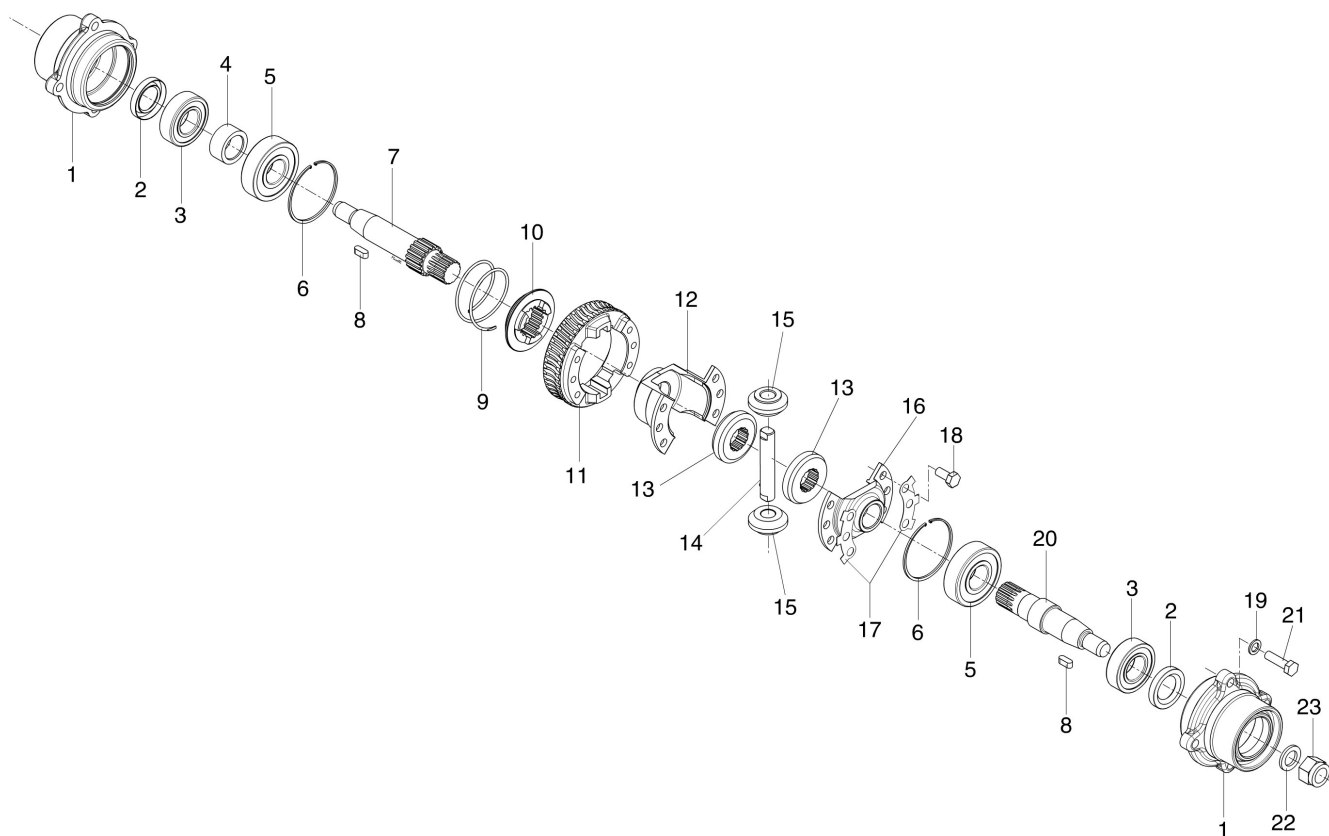

**KEES VAN DER SPEK**  
TUIN EN PARKMACHINES \* TER AAR

## Illustratie Achse mit differential

Bild Nr.	Anz.	Teilenummer	Beschreibung	Gültigkeit ab	Gültigkeit bis	Hinweis	Nachricht
1	2	YF1290209	Halter				
2	2	YN0209720	Ring				
3	2	YN1270701	Lager				
4	1	YF1290210	Distanzstück				
5	2	YN1272501	Lager				
6	2	028200031R	Seegerring				
7	1	YF1290207	Welle				
8	2	YN0646800	Keil				
9	1	YN3138800B	Feder				
10	1	YF1290201	Kappe				
11	1	YF1290205	Ritzel				
12	1	YF1290212	Halter				
13	2	YF1290203	Ritzel				
14	1	YF1290206	Stift				
15	2	YF1290202	Ritzel				
16	1	YF1290213	Halter				
17	2	YF1290204	Platte				
18	6	YN6254600	Schraube				
20	1	YF1290208	Welle				
21	8	322000001R	Schraube				
22	2	YN4403000	Grower				
23	2	YN1479800	Mutter				
19	8	YN4365400	Scheibe				

**KEES VAN DER SPEK**  
TUIN EN PARKMACHINES \* TER AAR



## Illustratie Bremsen und rader

Bild Nr.	Anz.	Teilenummer	Beschreibung	Gültigkeit ab	Gültigkeit bis	Hinweis	Nachricht
1	2	YN2382700	Aufnahmetrommel				
2	2	YF1290211	Radnabe				
3	4	YN2362700	Bremsbacke				
4	4	YN3105100	Feder				
5	2	YF1290220	Halb-aufnahmetrommel				
6	1	68350147R	Halb-aufnahmetrommel			Per freno Dx ; For RH brake	
7	2	3933032R	Mutter				
8	2	68350150R	Stift				
9	1	68350148R	Halb-aufnahmetrommel			Per freno Sx ; For LH brake	
10	8	YN4365400	Scheibe				
11	8	322000001R	Schraube				
12	2	69200098R	Vorderrad felger			4.00-8"	
12	2	69200109R	Vorderrad felger			4.00-10" Disco fisso ; Fixed	
13	2	69200099R	Vorderrad felger			disc 4.00-10" , 5.00-10" Disco	
13	8	3819014R	Grower				
14	2	68240153R	Vorderrad felger			16/6,50-8"	
14	8	YN6322000	Schraube				
15	2	YN4882500	Reifenschlauch			5.00-10"	
15	2	YN4881400	Reifenschlauch			16/6,50-8"	
15	2	YN4881100	Reifenschlauch			4.00-8"	
15	2	YN4881500	Reifenschlauch			4.00-10"	
16	2	YN4853500A	Reifen			5.00-10"	
16	2	YN4851880	Reifen			16/6,50-8"	
16	2	YN4851600	Reifen			4.00-8"	
16	2	YN4852000B	Reifen			4.00-10"	

**KEES VAN DER SPEK**  
TUIN EN PARKMACHINES \* TER AAR

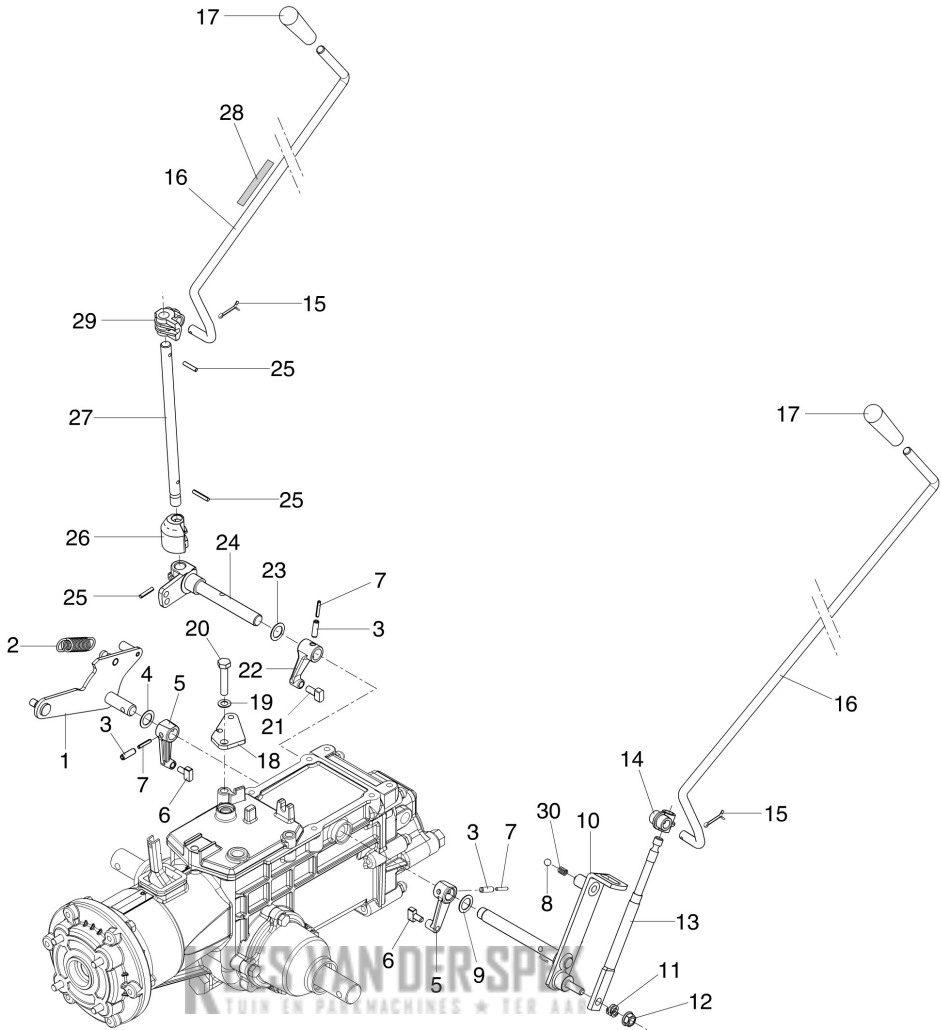

## Illustratie Innere schaltungen

Bild Nr.	Anz.	Teilenummer	Beschreibung	Gültigkeit ab	Gültigkeit bis	Hinweis	Nachricht
1	1	68350146AR	Nocken				
2	1	YN3118060	Feder				
3	1	YN5125500	Stift				
4	1	YN4394700	Distanzscheibe				
5	1	YF1291603	Hebel				
6	2	YF1291604	Gleitstueck				
7	3	YN5109300	Stift				
8	1	YN4745400	Kugel				
9	1	YK8401029	Scheibe				
10	1	YF1291613D	Bolzen				
11	1	YN3111500	Feder				
12	1	3933032R	Mutter				
13	1	68320152R	Hebel (Drehschalter)				
14	1	YF1061633	Befestigung (Lenker)				
15	2	YN1054900	Splint				
16	2	YF1291641A	Lenkholm				
17	2	YN3753600	Knopf				
18	1	68350145R	Streifen				
19	1	YN4365400	Scheibe				
20	1	3806076R	Schraube				
21	1	YF1050831	Gleitstueck				
22	1	YF1051700	Hebel				
23	1	YN4394700	Distanzscheibe				
24	1	YF1291613D	Bolzen				
25	3	YN5113800	Stift				
26	1	YF1241614	Sperre				
27	1	YF1291637B	Hebel				
28	1	68350009R	Markierung (PTO)				
29	1	YF1291633	Verbindung				
30	1	YN3104250	Feder				

**KEES VAN DER SPEK**  
TUIN EN PARKMACHINES \* TER AAR



## Illustratie Lenksaule und lenkholm

Bild Nr.	Anz.	Teilenummer	Beschreibung	Gültigkeit ab	Gültigkeit bis	Hinweis	Nachricht
1	1	68350133R	Deckung			Rossa ; Red	
2	1	YN6364510	Schraube				
3	1	68350088BR	Griff				
4	1	68350095R	Knopf				
5	1	68350142R	Feder			Dx ; Right	
6	1	68330249R	Hebel				
7	1	68350093R	Distanzstück				
8	1	68350143R	Feder			Sx ; Left	
9	3	68350114R	Stütze (Haube)				
10	1	68350100BR	Saeule				
11	2	3914001R	Mutter				
12	2	YN6357200	Schraube				
13	2	3058001R	Stossdaempfer				
14	1	68350091AR	Toranschluss lenksaule				
15	1	YN6345150	Schraube				
16	1	YN2605600	Fettnippel				
17	1	YN3109400	Feder				
18	1	68350152BR	Riegelbolzen				
19	1	68350109AR	Saeule-halterung				
20	1	YN5148800	Splint				
21	1	68640049R	Stift				
22	1	68350158AR	Drehschalter (Gangschaltanlage)				
23	4	3933032R	Mutter				
24	4	YF1430082	Buchse				
25	4	YN3815300	Stiftschraube				
26	1	68350003R	Markierung (Gangschaltanlage)				
27	2	3906075R	Schraube				
28	2	YF1255009D	Halter				
29	4	YN1458800	Mutter				
30	1	68350116R	Halter				
31	1	YK8197002	Stift				
32	2	034000013R	Mutter				
33	1	66060614R	Gummi				
34	1	68350179R	Einrichtung EHS				
35	1	3056375R	Markierung (Made in Italy)				
36	1	68350130R	Markierung (KAM7S)				
37	1	68250018R	Schild NIBBI				
38		68350007R	Markierung				
39	1	68350140R	Deckung				
40	1	68320272AR	Etikette				
41	1	68350230	Steuerungshebel			Inversore ; Inverter	
42	1	68350219R	Kabel			Da abbinare al	
43	1	68350103BR	Steuerungshebel			Blocco differenziale ; Differential lock (plc.66)	
44	2	3914006R	Mutter				

**KEES VAN DER SPEK**  
TUIN EN PARKMACHINES \* TER AAR

## Illustratie Lenksaule und lenkholm

Bild Nr.	Anz.	Teilenummer	Beschreibung	Gültigkeit ab	Gültigkeit bis	Hinweis	Nachricht
45	1	68320272AR	Etikette				
46	1	68350107AR	Steuerunghebel				Rotazione sterzo e freno Dx
47	2	68350196R	Markierung				
48	2	YN2847410	Griff start				
49	1	3044015AR	Schalter/Gashebel				Motore Diesel; Diesel engine
49	1	68350102R	Schalter/Gashebel				Motore benzina; Fuel
50	1	68350221R	Kabel				
51	1	68350220R	Kabel				Da abbinare al
52	1	68350008R	Markierung				
53	1	68350141R	Deckung				(pic.66)
54	1	68350224R	Kabel				Da abbinare al
55	1	68350222AR	Kabel				cod.F1370413 (rif.66); To be matched n/n.F1370413
56	1	68350223R	Kabel				Da abbinare al
57	1	68350176AR	Steuerunghebel				cod.F1370413 (rif.66); To be matched n/n.F1370413
58	1	68350083AR	Handgriff				Frizione; Clutch
59	1	3980002R	Mutter				
60	1	YN1463650	Mutter				
61	1	68310073R	Schalter				
62	1	68310074R	Feder				
63	1	3059018	Schelle				
64	2	68350067R	Spannstange				
65	1	68350211R	Etikette (Ergonomic handling system)				
66	1	F1370413	Sicherung				
67	2	3055055R	Bolzen (Sperre)				

**KEES VAN DER SPEK**  
TUIN EN PARKMACHINES \* TER AAR

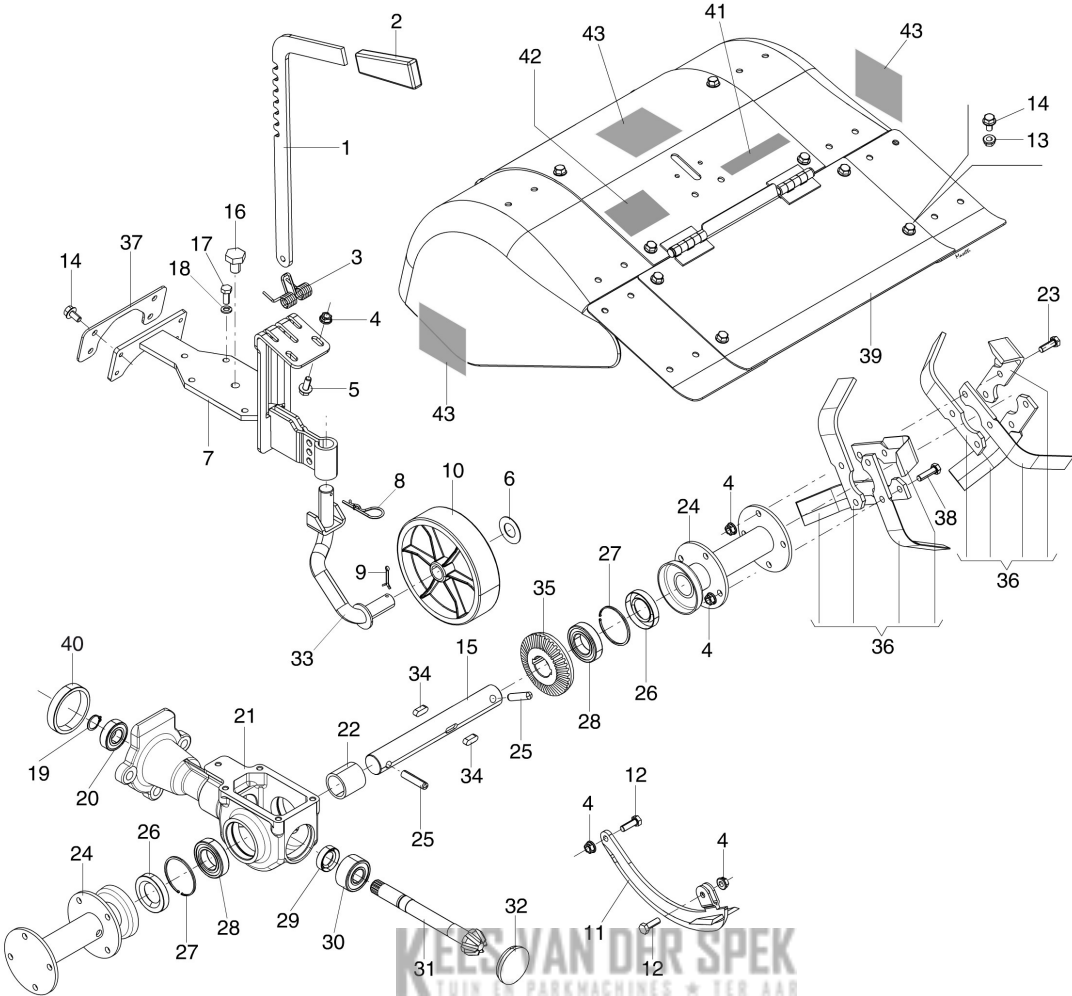

## Illustratie Frase 60 cm mit einstellbarer haube und Festanschluß 69219102

Bild Nr.	Anz.	Teilenummer	Beschreibung	Gültigkeit ab	Gültigkeit bis	Hinweis	Nachricht
1	1	69210262	Stange				
2	1	N2840490	Griff				
3	1	69210102R	Feder				
4	28	YN1457570	Mutter				
5	2	3906070R	Schraube				
6	1	N5003250	Distanzscheibe				
7	1	69210247R	Deckel				
8	1	N1054500	Splint				
9	1	YN1060200	Splint				
10	1	YK1102480	Support wheel				
11	1	YF0015592	Messer				
12	2	3806067R	Schraube				
13	12	3933032R	Mutter				
14	16	3933034R	Schraube				
15	1	F0017016D	Welle				
16	1	YN5254000	Oelpfropfen				
17	5	3906066R	Schraube				
18	5	3819013R	Grower				
19	1	3024020R	Seeger-ring				
20	1	YN1263201	Lager				
21	1	69210261R	Bodenfräse Gehäuse				
22	1	F0017018	Distanzstück			Filettatura DX; RH thread	
23	8	322000001R	Schraube				
24	2	YF0017005	Distanzstück				
25	2	YF0017024	Stift				
26	2	N0212450	Ring				
27	2	N0138000	Seeger-ring				
28	2	N1274500	Lager				
29	1	YN0207400	Ring				
30	1	N1264051	Lager				
31	1	YF0015581	Ritzel				
32	1	YN5276700	Stopfen				
33	1	K3501830	Halter				
34	2	N0651610	Schlüssel				
35	1	69210226R	Kranz				
36	1	R0000139	Messeren			Per fresa 70 cm, kit	
37	2	69210038R	Distanzstück				
38	8	3806074R	Schraube			10pz; For tiller 70 cm, set	
39	1	69210193R	Komplet Haube (60cm)			Colore Grigio; Grey color	
40	1	YF0013529	Buchse			LEFT, 10pcs	
41	1	3056374R	Markierung (Made in Italy)			Su richiesta; Upon request	
42	1	YF1233111	Markierung (Gefahr)			Su richiesta; Upon request	
43	3	69210220R	Markierung NIBBI			Su richiesta; Upon request	

**KEES VAN DER SPEK**  
TUIN EN PARKMACHINES - TER AAR

Illustratie Frase 60 cm mit einstellbarer haube und Quickfit 69219088

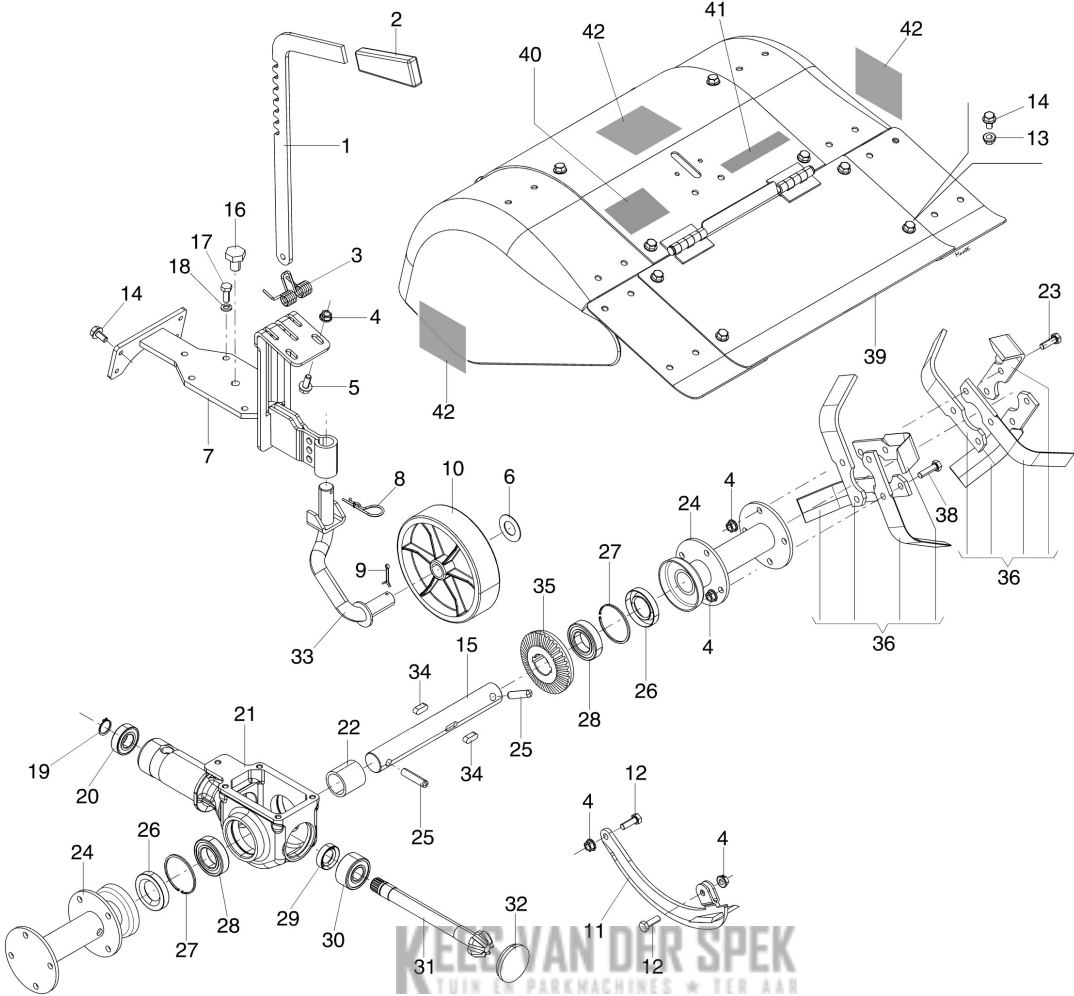

KEE VAN DER SPEK  
TUIN EN PARKMACHINES • TER AAR

# Illustratie Frase 60 cm mit einstellbarer haube und Quickfit 69219088

Bild Nr.	Anz.	Teilenummer	Beschreibung	Gültigkeit ab	Gültigkeit bis	Hinweis	Nachricht
1	1	69210262	Stange				
2	1	N2840490	Griff				
3	1	69210102R	Feder				
4	28	YN1457570	Mutter				
5	2	3906070R	Schraube				
6	1	N5003250	Distanzscheibe				
7	1	69210247R	Deckel				
8	1	N1054500	Splint				
9	1	YN1060200	Splint				
10	1	YK1102480	Support wheel				
11	1	YF0015592	Messer				
12	2	3806067R	Schraube				
13	12	3933032R	Mutter				
14	16	3933034R	Schraube				
15	1	F0017016D	Welle				
16	1	YN5254000	Oelpfropfen				
17	5	3906066R	Schraube				
18	5	3819013R	Grower				
19	1	3024020R	Seeger-ring				
20	1	YN1263201	Lager				
21	1	69212022AR	Bodenfräse Gehäuse				
22	1	F0017018	Distanzstück			Filettatura DX; RH thread	
23	8	322000001R	Schraube				
24	2	YF0017005	Distanzstück				
25	2	YF0017024	Stift				
26	2	N0212450	Ring				
27	2	N0138000	Seeger-ring				
28	2	N1274500	Lager				
29	1	YN0207400	Ring				
30	1	N1264051	Lager				
31	1	F0015583	Ritzel				
32	1	YN5276700	Stopfen				
33	1	K3501830	Halter				
34	2	N0651610	Schlüssel				
35	1	69210226R	Kranz				
36	1	R0000139	Messeren			Per fresa 70 cm, kit	
38	8	3806074R	Schraube				
39	1	69210193R	Komplet Haube (60cm)			Original, Grey color	
40	1	YF1233111	Markierung (Gefahr)			Su richiesta; Upon request	
41	1	3056374R	Markierung (Made in Italy)			LEFT HAND, Upon request	
42	3	69210220R	Markierung NIBBI			Su richiesta; Upon request	

**KEES VAN DER SPEK**  
TUIN EN PARKMACHINES - TER AAR

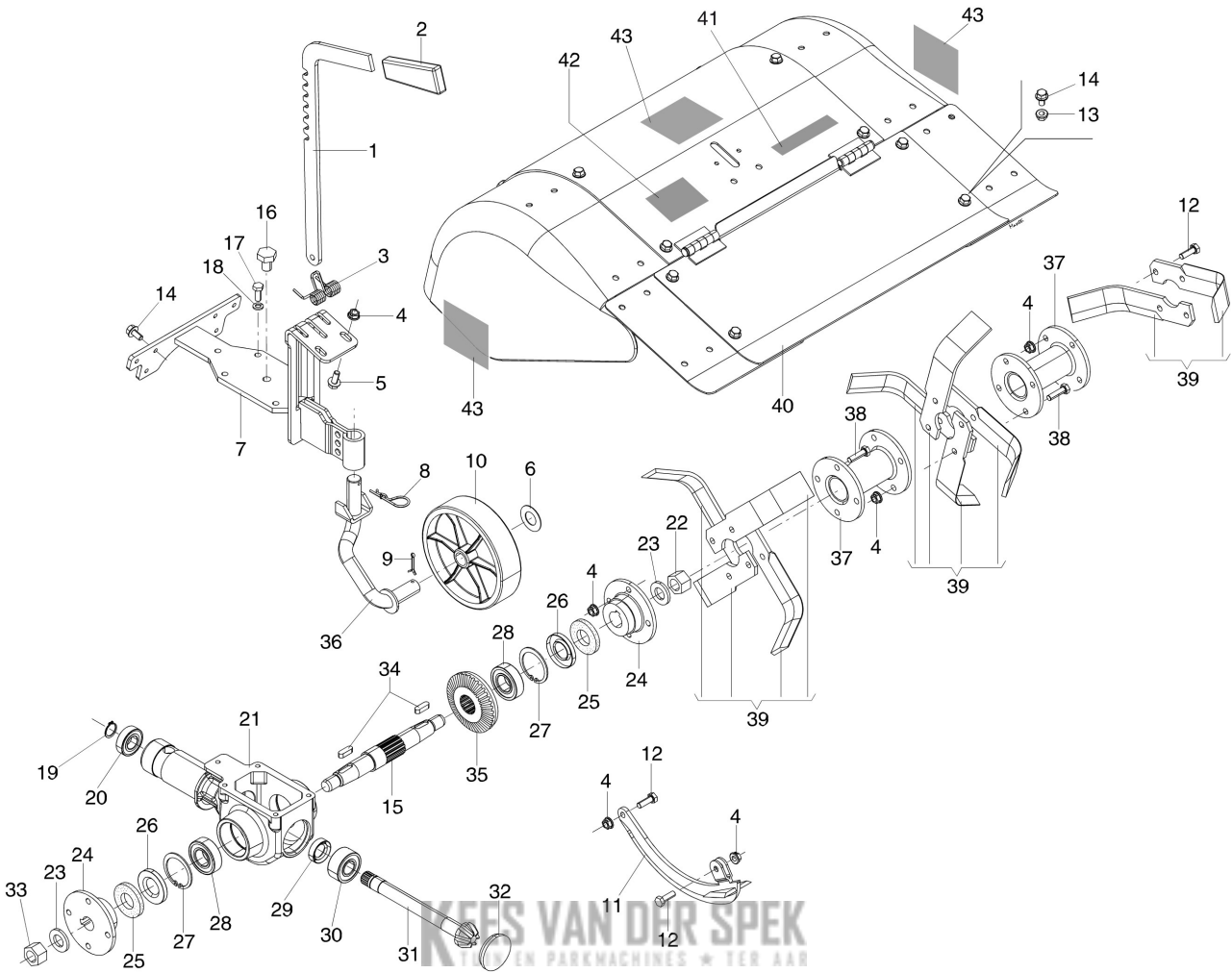

KES VAN DER SPEK  
TUIG EN PARKMACHINES \* TER AAR

# Illustratie Frase 70 cm mit einstellbarer haube und Quickfit 69219059

Bild Nr.	Anz.	Teilenummer	Beschreibung	Gültigkeit ab	Gültigkeit bis	Hinweis	Nachricht
1	1	69210262	Stange				
2	1	N2840490	Griff				
3	1	69210102R	Feder				
4	28	YN1457570	Mutter				
5	2	3906070R	Schraube				
6	1	N5003250	Distanzscheibe				
7	1	69210248R	Deckel				
8	1	N1054500	Splint				
9	1	YN1060200	Splint				
10	1	YK1102480	Support wheel				
11	1	YF0015592	Messer				
12	10	3806067R	Schraube				
13	12	3933032R	Mutter				
14	12	3933034R	Schraube				
15	1	YF0013531	Welle				
16	1	YN5254000	Oelpfropfen				
17	5	3906066R	Schraube				
18	5	3819013R	Grower				
19	1	3024020R	Seeger-ring				
20	1	YN1263201	Lager				
21	1	F0015541M	Bodenfräse Gehäuse				
22	2	N1482500	Mutter			Filettatura DX; RH thread	
23	2	N4418000	Scheibe				
24	2	69210246R	Halter				
25	2	YF0013525	Filz				
26	2	YN0210050	Dichtung				
27	2	YN0136800	Seeger-ring				
28	2	YN1270701	Lager				
29	1	YN0207400	Ring				
30	1	N1264051	Lager				
31	1	F0015583	Ritzel				
32	1	YN5276700	Stopfen				
33	1	N1482600	Mutter			Filettatura SX; LH thread	
34	2	YN0652200	Schlüssel				
35	1	F0015582	Kranz				
36	1	K3501830	Halter				
37	4	69210038R	Distanzstück				
38	16	N6274000	Schraube				
39	1	R0000138	Messeren			Per fresa 60/70 cm, kit composto da: F0015602, Color Grigio; Grey color	
40	1	69210139R	Komplet Haube (70cm)			DX. 1002 + F0015603. Sx.	
41	1	3056374R	Markierung (Made in Italy)			Su richiesta; Upon request	
42	1	YF1233111	Markierung (Gefahr)			F0015602, RIGHT, 10pcs + PH115613, Upon request	
43	3	69210220R	Markierung NIBBI			Su richiesta; Upon request	

**KEES VAN DER SPEK**  
TUIN EN PARKMACHINES • TER AAR



# Illustratie Frase 70 cm mit einstellbarer haube und Festanschluß 69219065

Bild Nr.	Anz.	Teilenummer	Beschreibung	Gültigkeit ab	Gültigkeit bis	Hinweis	Nachricht
1	1	69210262	Stange				
2	1	N2840490	Griff				
3	1	69210102R	Feder				
4	28	YN1457570	Mutter				
5	2	3906070R	Schraube				
6	1	N5003250	Distanzscheibe				
7	1	69210248R	Deckel				
8	1	N1054500	Splint				
9	1	YN1060200	Splint				
10	1	YK1102480	Support wheel				
11	1	YF0015592	Messer				
12	10	3806067R	Schraube				
13	12	3933032R	Mutter				
14	12	3933034R	Schraube				
15	1	YF0013531	Welle				
16	1	YN5254000	Oelpfropfen				
17	5	3906066R	Schraube				
18	5	3819013R	Grower				
19	1	3024020R	Seeger-ring				
20	1	YN1263201	Lager				
21	1	69210208AR	Bodenfräse Gehäuse				
22	2	N1482500	Mutter			Filettatura DX; RH thread	
23	2	N4418000	Scheibe				
24	2	69210246R	Halter				
25	2	YF0013525	Filz				
26	2	YN0210050	Dichtung				
27	2	YN0136800	Seeger-ring				
28	2	YN1270701	Lager				
29	1	YN0207400	Ring				
30	1	N1264051	Lager				
31	1	YF0015581	Ritzel				
32	1	YN5276700	Stopfen				
33	1	N1482600	Mutter			Filettatura SX; LH thread	
34	2	YN0652200	Schlüssel				
35	1	F0015582	Kranz				
36	1	K3501830	Halter				
37	4	69210038R	Distanzstück				
38	16	N6274000	Schraube				
39	1	R0000138	Messeren			Per fresa 70 cm, kit composto da: F0015602, DX. 10pz + F0015603. SX.	
40	1	YF0013529	Buchse				
41	1	69210139R	Komplet Haube (70cm)			Colore Grigio; Grey color composed by: F0015602, Su richiesta; Upon request	
42	1	3056374R	Markierung (Made in Italy)			RIGHT, 10pcs + F0015603, I FFT 10nrc	
43	1	YF1233111	Markierung (Gefahr)			Su richiesta; Upon request	
44	3	69210220R	Markierung NIBBI			Su richiesta; Upon request	



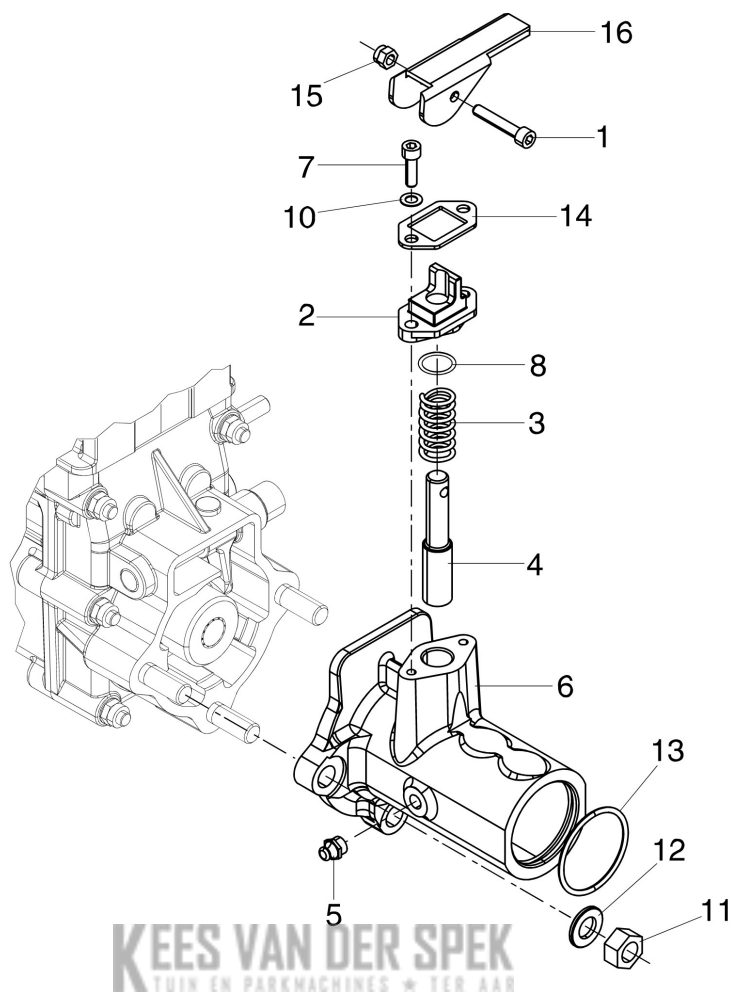

## Illustratie Quickfit 69212006

Bild Nr.	Anz.	Teilenummer	Beschreibung	Gültigkeit ab	Gültigkeit bis	Hinweis	Nachricht
1	1	3801027R	Schraube				
2	1	YF1294702	Führung				
3	1	YN3118700	Feder				
4	1	YF1054710	Riegelbolzen				
5	1	YN2605600	Fettnippel				
6	1	69210090AR	Flansch				
7	2	3801022R	Schraube				
8	1	3049016R	O-ring				
10	2	YN4358110	Scheibe				
11	3	YN1470500	Mutter				
12	3	YN4387700	Scheibe				
13	1	YK7035045	O-ring				
14	1	YF1294701	Streifen				
15	1	3914008R	Mutter				
16	1	YF1294700	Hebel				

**KEES VAN DER SPEK**  
TUIN EN PARKMACHINES \* TER AAR

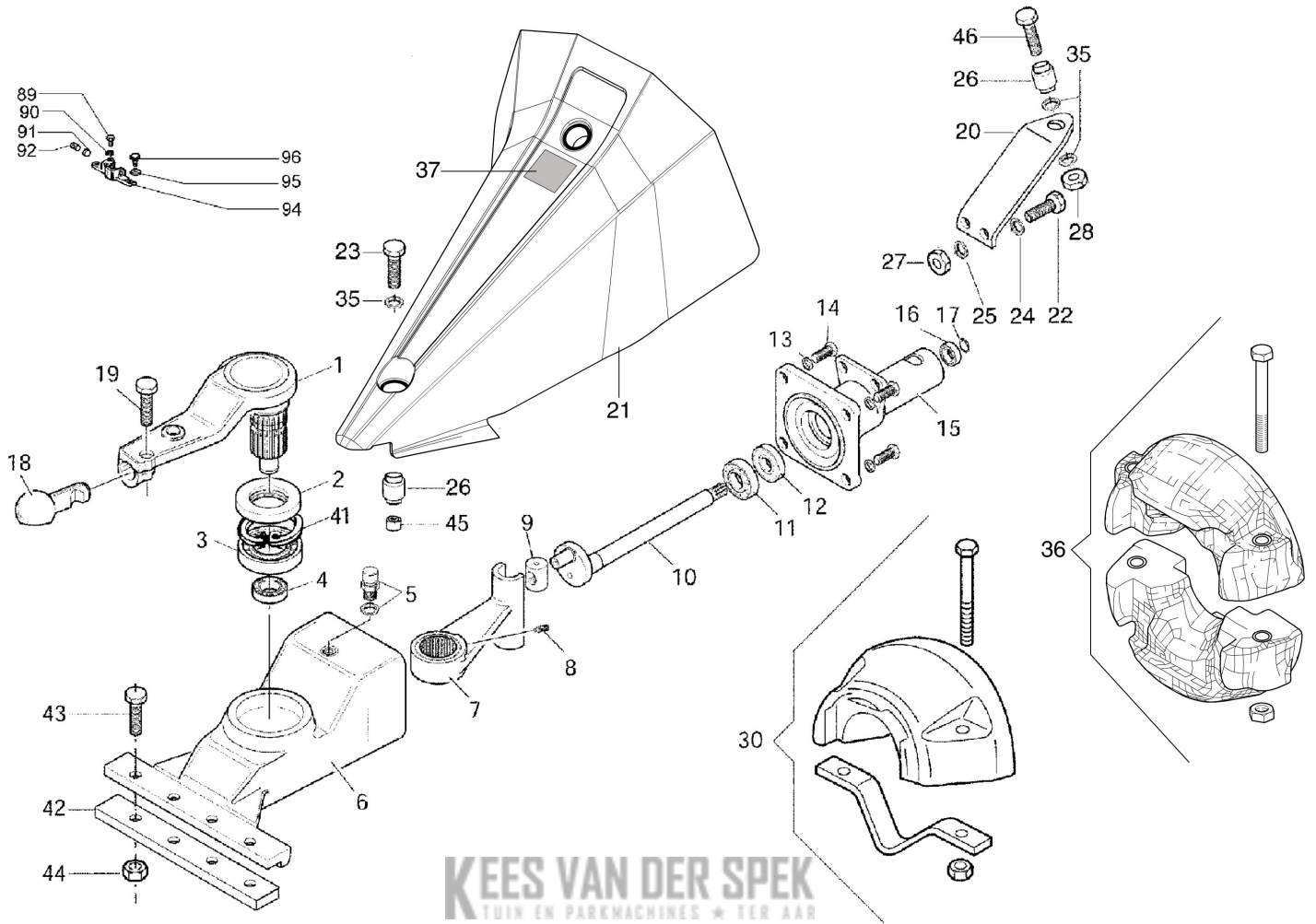

# Illustratie Oil bath movement 69229097

Bild Nr.	Anz.	Teilenummer	Beschreibung	Gültigkeit ab	Gültigkeit bis	Hinweis	Nachricht
1	1	69220059R	Pleuel (Extern)				
2	1	YN0222805	Ring				
3	1	YN1289200	Lager				
4	1	YN1263701	Lager				
5	1	YK4101420	Stopfen				
6	1	F1303100B	Gehaeuse				
7	1	F1303102D	Pleuel				
8	1	N6251000	Schraube				
9	1	YF1303106	Schalter				
10	1	F1303108	Welle				
11	1	YN1272501	Lager				
12	1	YN0210045	Ring				
13	1	3819014R	Grower				
14	1	3806094R	Schraube				
15	1	F1303101B	Deckel				
16	1	YN1263201	Lager				
17	1	3024020R	Seeger-ring				
18	1	YF1303155B	Stift				
19	1	3806094R	Schraube				
20	1	F1303125	Halter				
21	1	69220050BR	Haube			Rosso ; Red	
22	1	3806067R	Schraube				
23	1	YN6402600	Schraube				
24	1	3819013R	Grower				
25	1	3916008R	Scheibe				
26	1	N4924000	Silentblock				
27	1	320000028R	Mutter				
28	1	YN1470200	Mutter				
30	1	L0105700	Satz (Ballast)			Singola ; Single	
35	1	3916012R	Scheibe				
36	1	L0102300	Satz (Ballast)			Doppia ; Double	
37	1	68250018R	Schild NIBBI				
41	1	N0140800	Seeger-ring				
42	1	L0081100	Distanzscheibe				
43	1	YN6332800	Schraube				
44	1	YN1463650	Mutter				
45	1	F1303133	Distanzstück				
46	1	N6399710	Schraube				
89	1	YN6262200	Schraube				
90	1	3819013R	Grower				
91	1	YF1073364	Anlaufscheibe				
92	1	N6433900	Schraube				
94	1	YF1073363B	Mitnehmer				
95	1	3819013R	Grower				
96	1	3806063	Schraube				

**KEES VAN DER SPEK**  
TUIN EN PARKMACHINES - TER AAR

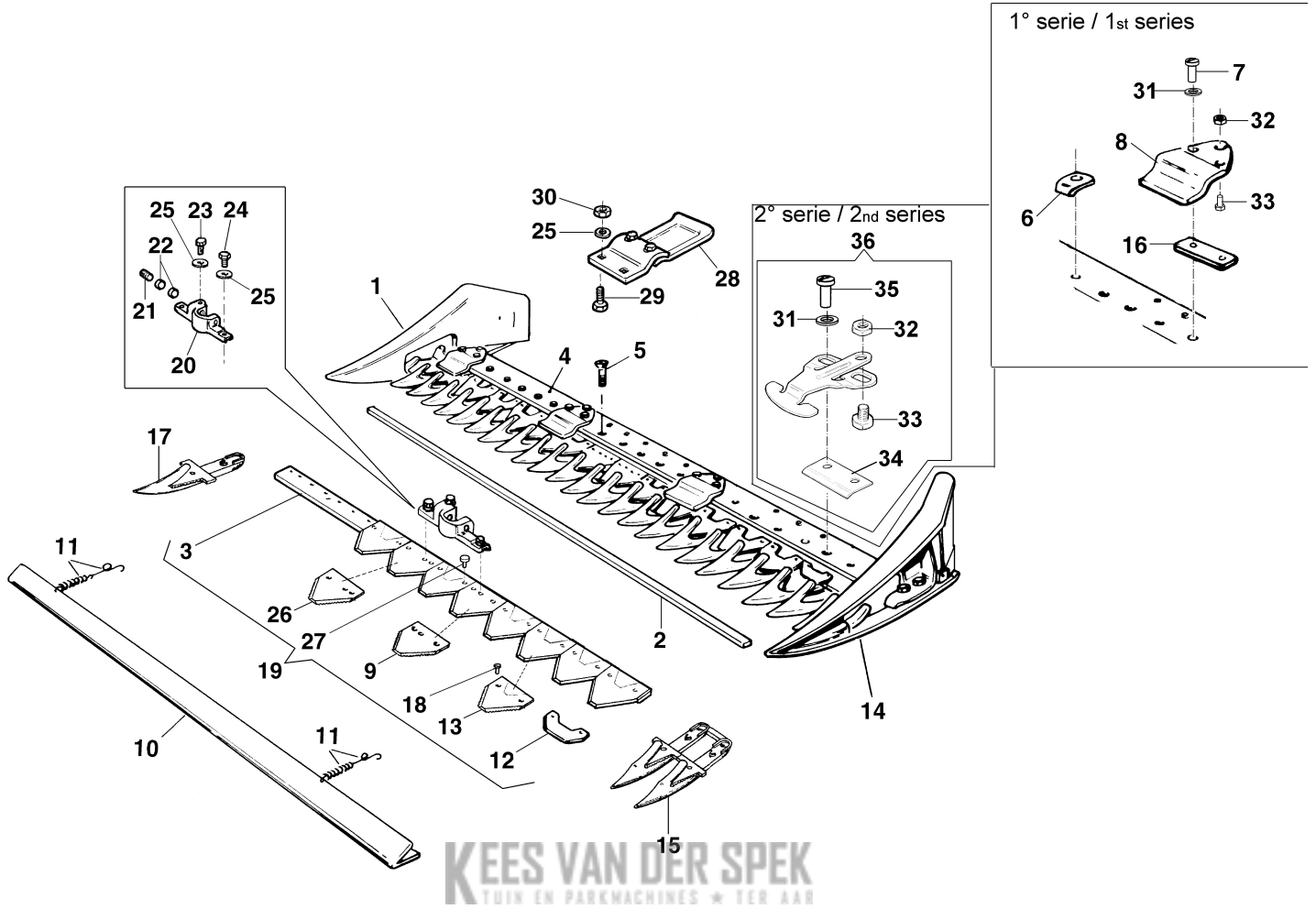

# Illustratie Mulchbalken 69229084/69229085/69229086/69229087

Bild Nr.	Anz.	Teilenummer	Beschreibung	Gültigkeit ab	Gültigkeit bis	Hinweis	Nachricht
1	1	69229098	Pair of directional guides for cutterbar			DX; RIGHT	
2	1	69220017	Stange			1150 mm	
2	1	F1073220	Führung			1450 mm	
2	1	F0591593	Führung			1270 mm	
2	1	F0712027	Führung			950 mm	
3	1	69220023	Stange				
4	1	F1303116	Platte			950 mm	
4	1	F1303117	Platte			1150 mm	
4	1	F1303118	Platte			1270 mm	
4	1	F1303119	Platte			1450 mm	
5	15	YN6325400	Schraube				
6	4	69220018	Halter		31/12/2013	Per barre / for bars:	BT6-006-07/14
7	8	3906099	Schraube		31/12/2013	Per barre / for bars:	BT6-006-07/14
8	4	69220047	Satz presse-Blatt		31/12/2013	69229039/69229040/69229041/69229042 Per barre / for bars:	BT6-006-07/14
9	1	F1073377R	Blatt				
10	-		Nicht verfügbar für diesen produkt				
11	-		Nicht verfügbar für diesen produkt				
12	13	F1073317	Streifen				
13	13	YF0582091	Blatt				
14	1	69229098	Pair of directional guides for cutterbar			SX; LEFT	
15	11	F0582688	Zahn (Doppelt)				
16	12	LS621107	Distanzstück			Per barre / for bars:	BT6-006-07/14
17	1	F0582738	Zahn (Einzel)				
18	28	YN0886600	Niete				
19	1	YF1073385	Blatt			1270 mm SF	
19	1	YF1073386	Blatt			1450 mm SF	
19	1	YF1073384	Blatt			1150 mm SF	
19	1	YF1073383	Blatt			950 mm SF	
20	1	YF1073376B	Mitnehmer				
21	1	N6433900	Schraube				
22	2	YF1073364	Anlaufscheibe				
23	1	YN6262200	Schraube				
24	2	3806063	Schraube				
25	7	3819013R	Grower				
26	1	F1073378R	Blatt				
27	2	F1073261	Niete				
28	2	69220024R	Komplette der schlitten				
29	8	3806070R	Schraube				
30	8	320000028R	Mutter				
31	8	3916010R	Scheibe				BT6-006-07/14
32	4	N1462800	Mutter				BT6-006-07/14
33	4	N6314900	Schraube				BT6-006-07/14
34	4	LS621197	Presse-blatt	01/01/2014			BT6-006-07/14
35	8	N6333300	Schraube	01/01/2014			BT6-006-07/14

**KEES VAN DER SPEK**  
TUIN EN PARKMACHINES - TER AAR

Bild Nr.	Anz.	Teilenummer	Beschreibung	Gültigkeit ab	Gültigkeit bis	Hinweis	Nachricht
36	4	69220047	Satz presse-Blatt	01/01/2014			BT6-006-07/14

**KEES VAN DER SPEK**  
TUIN EN PARKMACHINES ★ TER AAR

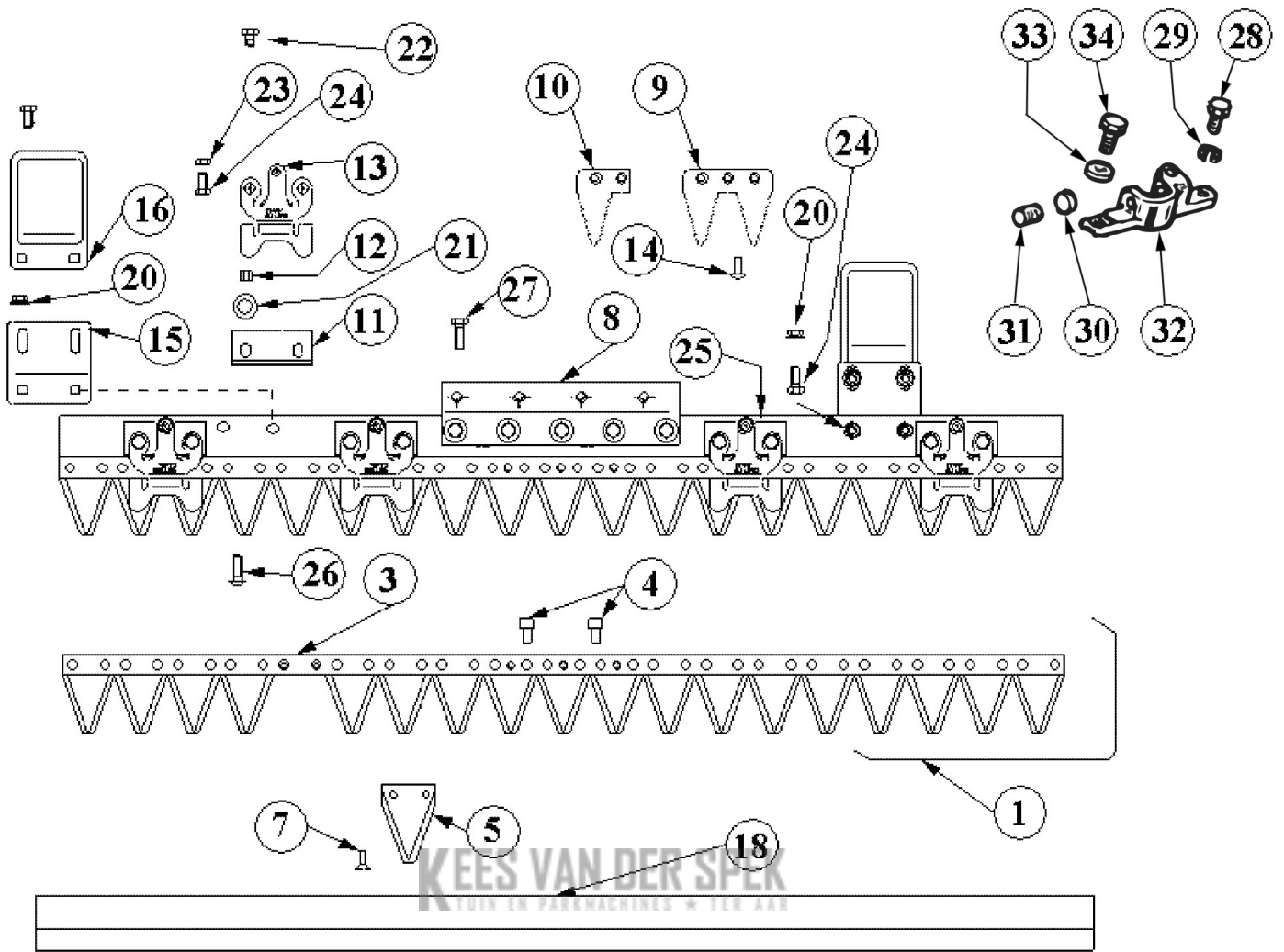

# Illustratie Balken 69229068/69229069/69229070/69229071

Bild Nr.	Anz.	Teilenummer	Beschreibung	Gültigkeit ab	Gültigkeit bis	Hinweis	Nachricht
1	1	YLS471906	Komplette Blatt			97 cm	
1	1	YLS472306	Komplette Blatt			117 cm	
1	1	YLS472506	Komplette Blatt			127 cm	
1	1	YLS472906	Komplette Blatt			147 cm	
3	1	LS3419225	Stange				
4	1	LS625231	Bolzen				
5	19	LS310067	Blatt			3 fori; 3 holes	
7	36	LS213611	Niete				
8	1	LS627027	Platte				
9	9	LS623122	Zahn (Doppelt)			Dente doppio; Double tooth	
10	1	LS623124	Zahn (Einzel)			Dente singolo; Singolo tooth	
11	6	LS621139	Blatthalter				
12	12	LS621135	Distanzstück				
13	6	LS621230	Presse-Blatt				
14	24	LS215619R	Niete				
15	2	LS621136	Halter				
16	2	LS621172	Gleitstueck				
18	1	LS625056	Schultz 97 cm			97 cm	
18	1	LS625061	Schultz cm 117			117 cm	
18	1	LS625062	Schultz cm 127			127 cm	
18	1	LS625064	Schultz cm 147			147 cm	
20	8	LS7060008	Mutter				
21	12	3916008R	Scheibe				
22	12	LS7000810	Schraube				
23	6	320000028R	Mutter				
24	4	LS7190825	Schraube				
25	1	LS62692310	Complete cutter plate			97 cm	
25	1	LS626918	Platte			117 cm	
25	1	LS626924	Platte			127 cm	
25	1	LS626925	Platte			147 cm	
26	12	LS7190822	Schraube				
27	5	3806063	Schraube				
28	1	YN6262200	Schraube				
29	1	3819013R	Grower				
30	1	YF1073364	Anlaufscheibe				
31	1	N6433900	Schraube				
32	1	YF1073363B	Mitnehmer				
33	1	3819013R	Grower				
34	1	3806063	Schraube				

**KEES VAN DER SPEK**  
TUIN EN PARKMACHINES - TER AAR

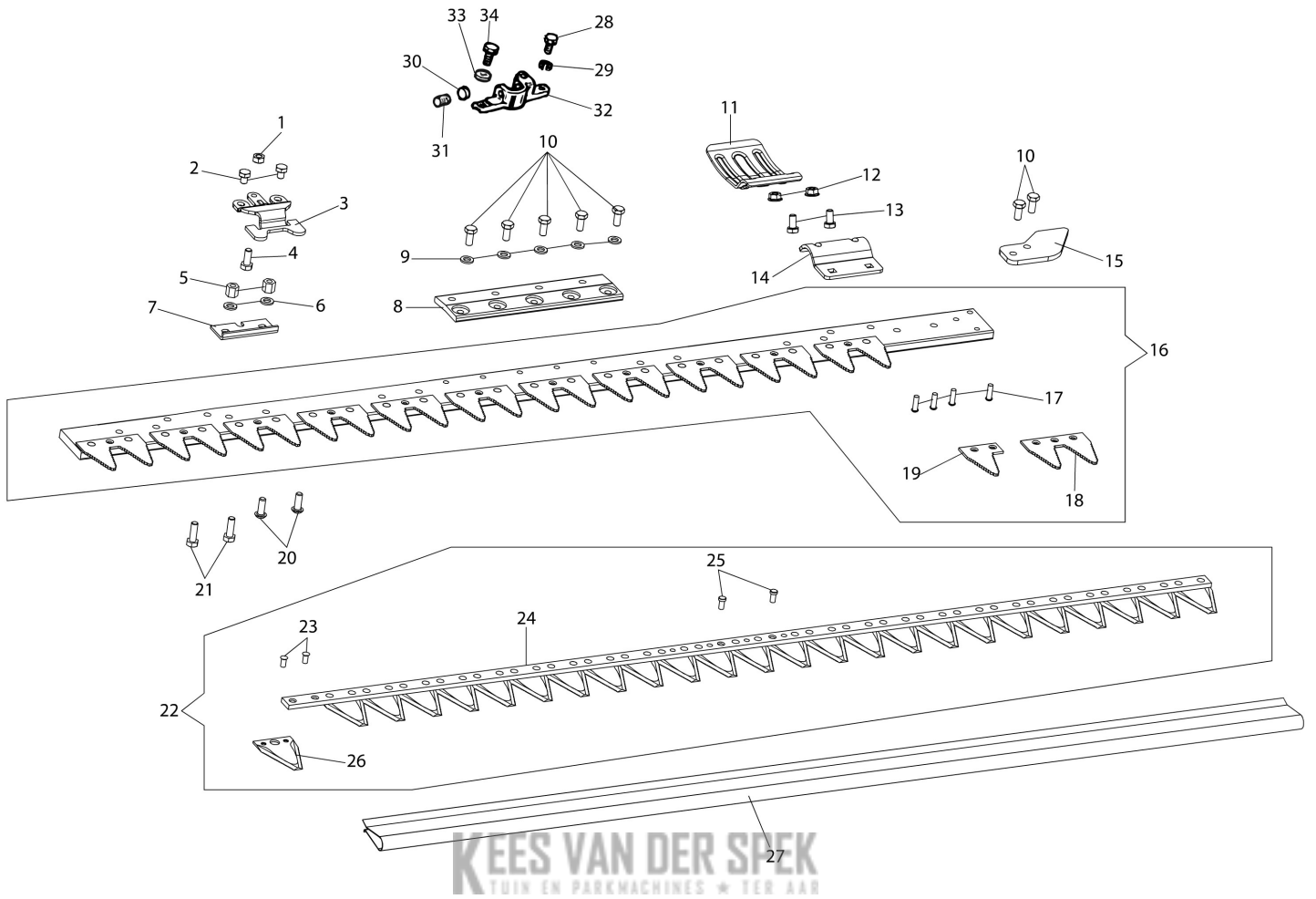

# Illustratie Mulchbalken 69229068A/69229069A/69229070A/69229071A

Bild Nr.	Anz.	Teilenummer	Beschreibung	Gültigkeit ab	Gültigkeit bis	Hinweis	Nachricht
1	6	LS7020008	Mutter				
2	12	028200039R	Schraube				
3	6	LS621230	Presse-Blatt				
4	6	3906066R	Schraube				
5	12	LS621135	Distanzstück				
6	12	3916008R	Scheibe				
7	6	LS621139	Blatthalter				
8	1	LS627027	Platte				
9	5	LS7092901	Scheibe				
10	9	YN6254600	Schraube				
11	2	LS621172	Gleitstueck				
12	8	3933032R	Mutter				
13	4	3806063	Schraube				
14	2	LS621136	Halter				
15	2	LS624058	Schultz				
16	1	LS62692410	Complete cutter plate			127 cm	
16	1	LS62692310	Complete cutter plate			97 cm	
16	1	LS62691810	Complete cutter plate			117 cm	
16	1	LS62692510	Complete cutter plate			147 cm	
17	24	LS215619R	Niete				
18	12	LS623122	Zahn (Doppelt)				
19	1	LS623124	Zahn (Einzel)				
20	12	LS7190822	Schraube				
21	4	3806067R	Schraube				
22	1	YLS472306	Komplette Blatt			117 cm	
22	1	YLS472906	Komplette Blatt			147 cm	
22	1	YLS472506	Komplette Blatt			127 cm	
22	1	YLS471906	Komplette Blatt			97 cm	
23	48	LS213612R	Niete				
24	1	LS3425225	Stange				
25	2	LS625231	Bolzen				
26	25	LS310067	Blatt				
27	1	LS625061	Schultz cm 117			117 cm	
27	1	LS625064	Schultz cm 147			147 cm	
27	1	LS625062	Schultz cm 127			127 cm	
27	1	LS625056	Schultz 97 cm			97 cm	
28	1	YN6262200	Schraube				
29	1	3819013R	Grower				
30	1	YF1073364	Anlaufscheibe				
31	1	N6433900	Schraube				
32	1	YF1073363B	Mitnehmer				
33	1	3819013R	Grower				
34	1	3806063	Schraube				

**KEES VAN DER SPEK**  
TUIN EN PARKMACHINES • TER AAR

esm universal 102/122 clip clap

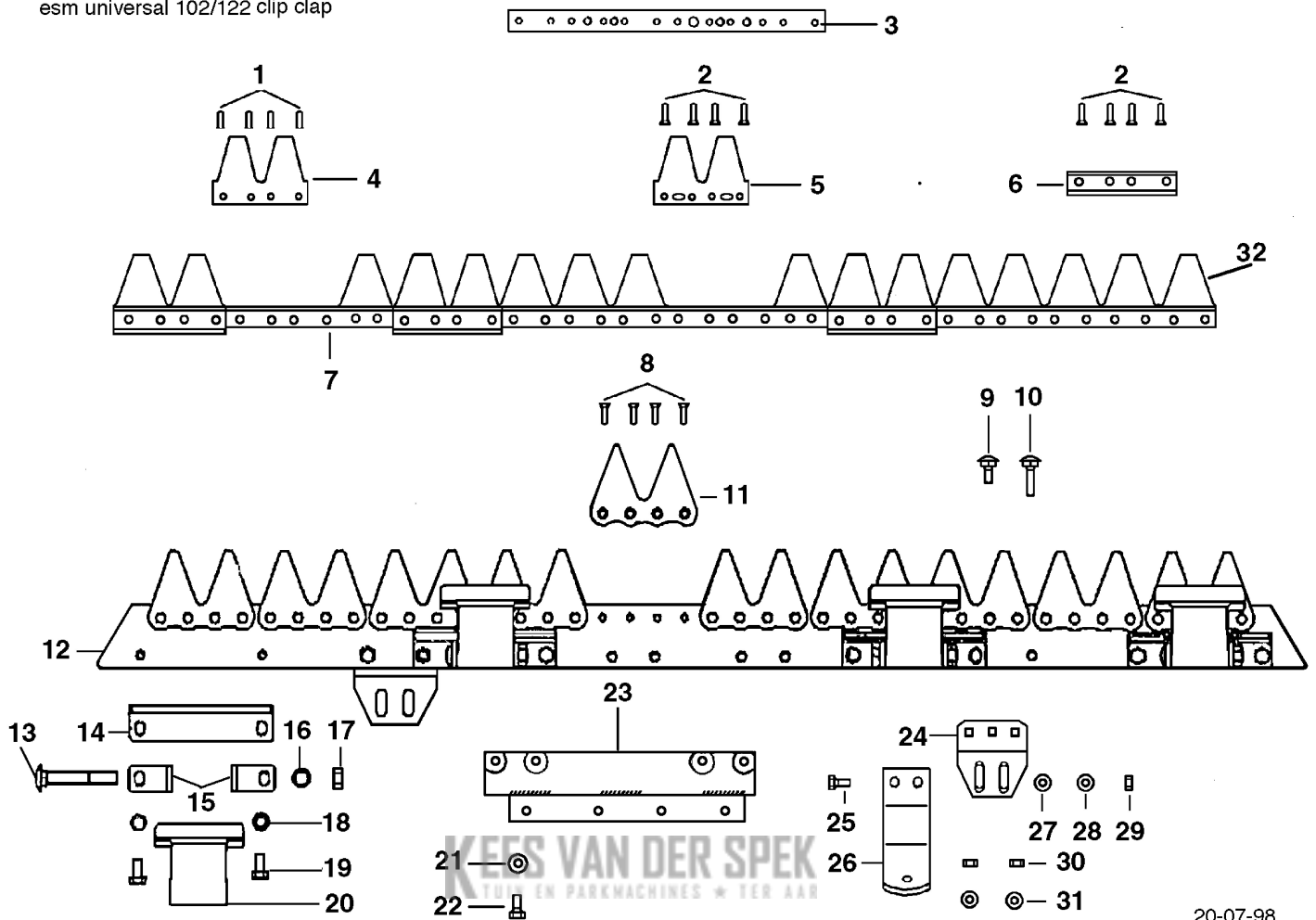

20-07-98

## Illustratie Balken "UNIVERSAL" 69229035/69229036

Bild Nr.	Anz.	Teilenummer	Beschreibung	Gültigkeit ab	Gültigkeit bis	Hinweis	Nachricht
1	1	R1504705	Niete				
2	1	R1504706	Niete				
3	1	F1073501	Verstaerkung				
4	1	F1073451	Scherenmesser (Doppelt)				
5	1	F1073452	Scherenmesser (Doppelt)				
6	1	F1073453	Führung				
7	1	YF1073468	Scherenmesser			122 cm	
7	1	F1073502	Buchrücken (Klinge)			102 cm	
8	1	N0892500	Niete				
9	-		Nicht verfügbar für diesen produkt				
10	-		Nicht verfügbar für diesen produkt				
11	1	F1073456	Zahn (Doppelt)				
12	1	F1073505	Buchrücken (Stange)			102 cm	
12	1	F1073506	Buchrücken (Stange)			122 cm	
13	1	F1073462	Schraube				
14	1	F1073458	Platte				
15	1	F1073459	Winkel				
16	-		Nicht verfügbar für diesen produkt				
17	1	N1464800	Mutter				
18	-		Nicht verfügbar für diesen produkt				
19	1	3806063	Schraube				
20	1	F1073457	Einstosser				
21	1	YN4365400	Scheibe				
22	1	YN6254600	Schraube				
23	1	F1073401	Anschlussplatte				
24	1	F1073430	Befestigung (Sohle)				
25	1	3806067R	Schraube				
26	1	F1073428	Sohle				
27	1	3916008R	Scheibe				
28	1	YN4365400	Scheibe				
29	1	R1504723	Mutter				
30	-		Nicht verfügbar für diesen produkt				
31	-		Nicht verfügbar für diesen produkt				
32	1	YF1073467	Scherenmesser			102 cm	
32	1	YF1073468	Scherenmesser			122 cm	

**KEES VAN DER SPEK**  
TUIN EN PARKMACHINES - TER AAR

esm universal 102/122/142 clip clap

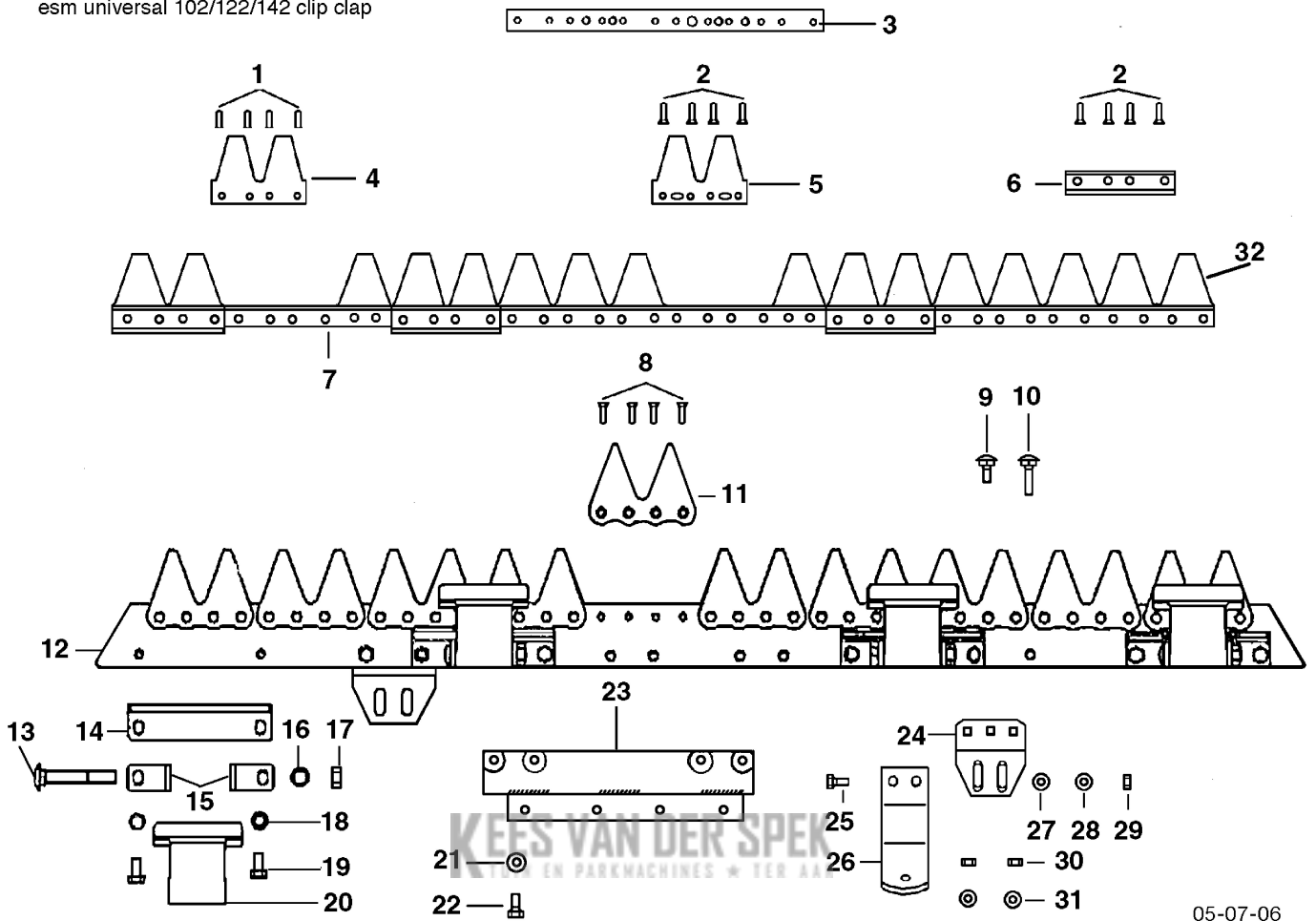

05-07-06

# Illustratie Balken "clip clap" 69229035/69229036/69229021

Bild Nr.	Anz.	Teilenummer	Beschreibung	Gültigkeit ab	Gültigkeit bis	Hinweis	Nachricht
1	1	R1504705	Niete				
2	1	R1504706	Niete				
3	1	F1073501	Verstaerkung				
4	1	F1073451	Scherenmesser (Doppelt)				
5	1	F1073452	Scherenmesser (Doppelt)				
6	1	F1073453	Führung				
7	1	F1073504	Buchrücken (Klinge)			142 cm	
7	1	F1073502	Buchrücken (Klinge)			102 cm	
7	1	YF1073468	Scherenmesser			122 cm	
8	1	N0892500	Niete				
9	-		Nicht verfügbar für diesen produkt				
10	-		Nicht verfügbar für diesen produkt				
11	1	F1073456	Zahn (Doppelt)				
12	1	F1073506	Buchrücken (Stange)			122 cm	
12	1	F1073507	Buchrücken (Stange)			142 cm	
12	1	F1073505	Buchrücken (Stange)			102 cm	
13	1	F1073462	Schraube				
14	1	F1073458	Platte				
15	1	F1073459	Winkel				
16	-		Nicht verfügbar für diesen produkt				
17	1	N1464800	Mutter				
18	-		Nicht verfügbar für diesen produkt				
19	1	3806063	Schraube				
20	1	F1073457	Einstosser				
21	1	YN4365400	Scheibe				
22	1	YN6254600	Schraube				
23	1	F1073401	Anschlussplatte				
24	1	F1073430	Befestigung (Sohle)				
25	1	3806067R	Schraube				
26	1	F1073428	Sohle				
27	1	3916008R	Scheibe				
28	1	YN4365400	Scheibe				
29	1	R1504723	Mutter				
30	-		Nicht verfügbar für diesen produkt				
31	-		Nicht verfügbar für diesen produkt				
32	1	YF1073467	Scherenmesser			102 cm	
32	1	YF1073468	Scherenmesser			122 cm	
32	1	F1073469	Scherenmesser			142 cm	

**KEES VAN DER SPEK**  
TUIN EN PARKMACHINES - TER AAR

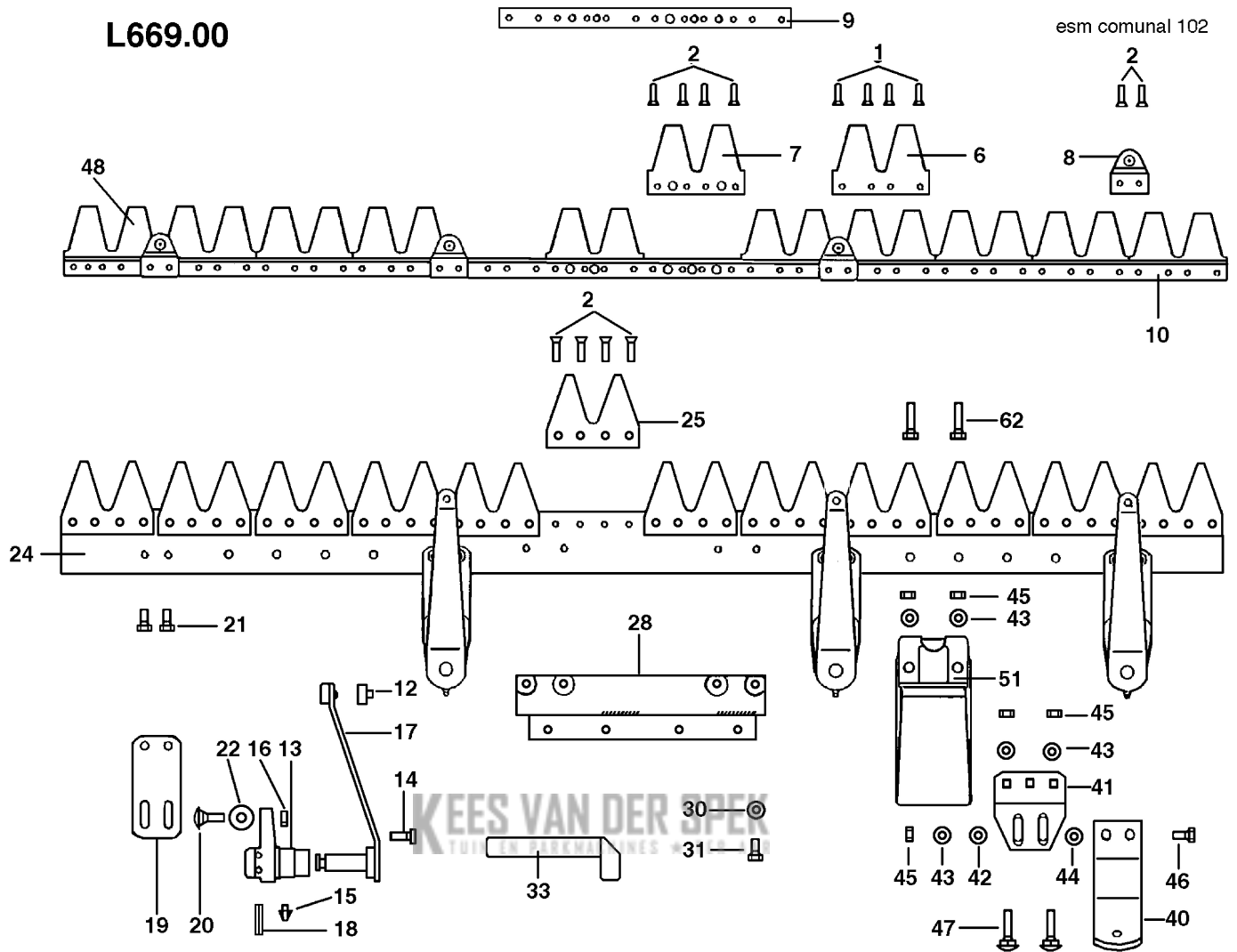

## Illustratie Mähbalken L0066900

Bild Nr.	Anz.	Teilenummer	Beschreibung	Gültigkeit ab	Gültigkeit bis	Hinweis	Nachricht
1	1	R1504705	Niete				
2	1	R1504706	Niete				
6	1	F1073451	Scherenmesser (Doppelt)				
7	1	F1073452	Scherenmesser (Doppelt)				
8	1	R1504764	Halter				
9	1	F1073438	Verstaerkung				
10	1	F1073525	Buchrücken (Klinge)			102 cm	
12	1	R1504773	Lager				
13	1	R1504768	Halter				
14	1	R1504769	Schraube				
15	1	R1504770	Fettnippel				
16	1	R1504723	Mutter				
17	1	R1504772	Schwungarm				
18	1	R1504771	Stift				
19	1	F1073436	Platte				
20	1	F1073442	Schraube				
21	1	YN6249300	Schraube				
22	1	3916010R	Scheibe				
24	1	F1073526	Buchrücken (Stange)			102 cm	
25	1	F1073456	Zahn (Doppelt)				
28	1	F1073401	Anschlussplatte				
30	1	YN4365400	Scheibe				
31	1	YN6254600	Schraube				
33	1	F1073415	Hebel (Montage)				
40	1	F1073428	Sohle				
41	1	F1073430	Befestigung (Sohle)				
42	1	3916008R	Scheibe				
43	1	YN4365400	Scheibe				
44	1	F1073443	Scheibe				
45	1	R1504723	Mutter				
46	1	3806067R	Schraube				
47	1	R1504720	Schraube				
48	1	F1073524	Blatt			102 cm	
51	1	F1073432	Gleitschuh				
62	1	3806070R	Schraube				

**KEES VAN DER SPEK**  
TUIN EN PARKMACHINES • TER AAR

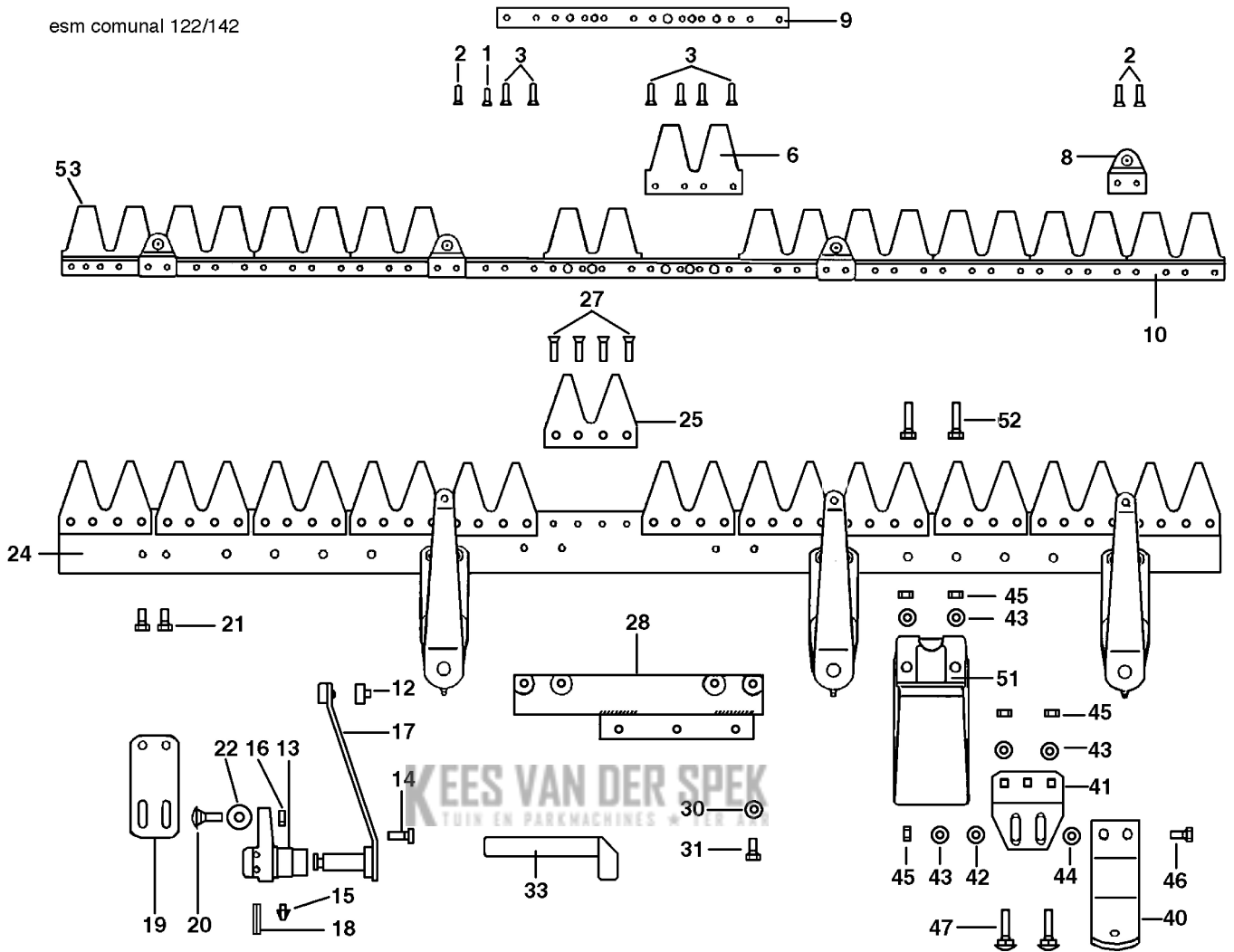

# Illustratie Mulchbalken "COMUNAL" 69229037/69229038

Bild Nr.	Anz.	Teilenummer	Beschreibung	Gültigkeit ab	Gültigkeit bis	Hinweis	Nachricht
1	1	R1504705	Niete				
2	1	R1504706	Niete				
3	1	F1073441	Niete				
6	1	R1504709	Scherenmesser (Doppelt)				
8	1	R1504764	Halter				
9	1	F1073438	Verstaerkung				
10	-		Nicht verfügbar für diesen produkt				
12	1	R1504773	Lager				
13	1	R1504768	Halter				
14	1	R1504769	Schraube				
15	1	R1504770	Fettnippel				
16	1	R1504723	Mutter				
17	1	R1504772	Schwungarm				
18	1	R1504771	Stift				
19	1	F1073436	Platte				
20	1	F1073442	Schraube				
21	1	YN6249300	Schraube				
22	1	3916010R	Scheibe				
24	1	F1073417	Buchrücken (Stange)			122 cm	
24	1	F1073418	Buchrücken (Stange)			142 cm	
25	1	F1073456	Zahn (Doppelt)				
27	1	N0892500	Niete				
28	1	F1073401	Anschlussplatte				
30	1	YN4365400	Scheibe				
31	1	YN6254600	Schraube				
33	1	F1073415	Hebel (Montage)				
40	1	F1073428	Sohle				
41	1	F1073430	Befestigung (Sohle)				
42	1	3916008R	Scheibe				
43	1	YN4365400	Scheibe				
44	1	F1073443	Scheibe				
45	1	R1504723	Mutter				
46	1	3806067R	Schraube				
47	1	R1504720	Schraube				
51	1	F1073432	Gleitschuh				
52	1	3806070R	Schraube				
53	1	YF1073409	Scherenmesser			122 cm	
53	1	F1073410	Scherenmesser			142 cm	

**KEES VAN DER SPEK**  
TUIN EN PARKMACHINES \* TER AAR

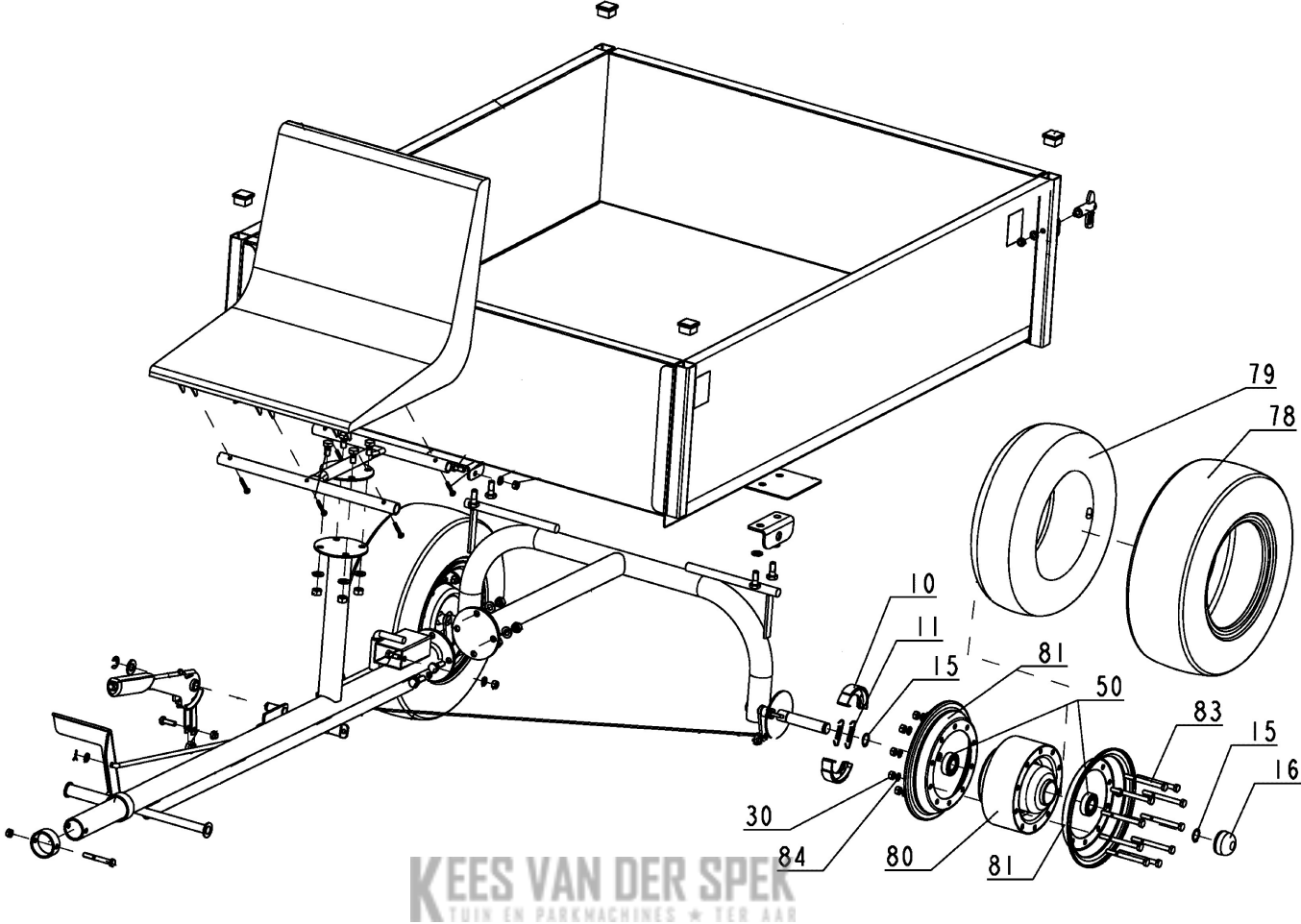

## Illustratie Towed trailer L0018601

---

Bild Nr.	Anz.	Teilenummer	Beschreibung	Gültigkeit ab	Gültigkeit bis	Hinweis	Nachricht
10	1	MR000001	Greifbacken				
11	1	MR000002	Feder				
15	1	MR000003	Mutter				
16	1	MR000004	Stopfen				
30	1	MR000005	Mutter				
50	1	MR000006	Lager				
78	1	MR000007	Reifen				
79	1	MR000008	Reifenschlauch				
80	1	MR000009	Aufnahmetrommel				
81	1	MR000010	Vorderrad felger				
83	1	MR000011	Schraube				
84	1	MR000012	Scheibe				

**KEES VAN DER SPEK**  
TUIN EN PARKMACHINES \* TER AAR