

KEES VAN DER SPEK  
TUIN EN PARKMACHINES \* TER AAN

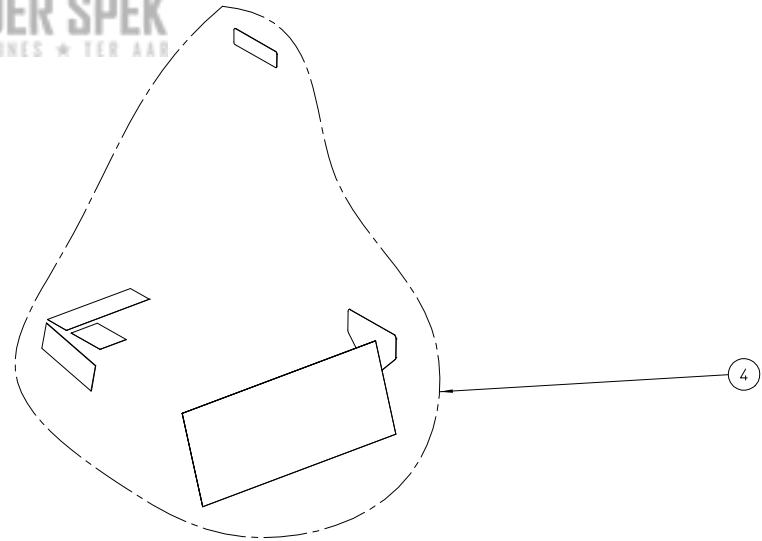

E401 -- ECO LINER					
NO	MA 007 040 121	REV	1	DATE	2016/03/01

#	Bestelnummer	Omschrijving	Aantal
1	MMA 01 080 221	rubberen wiel	1
2	MMA 01 080 112	rotor eco liner	1
3	MMA 01 080 231	stuur eco liner	1
4	MMA 01 080 405	klevers eco liner	1

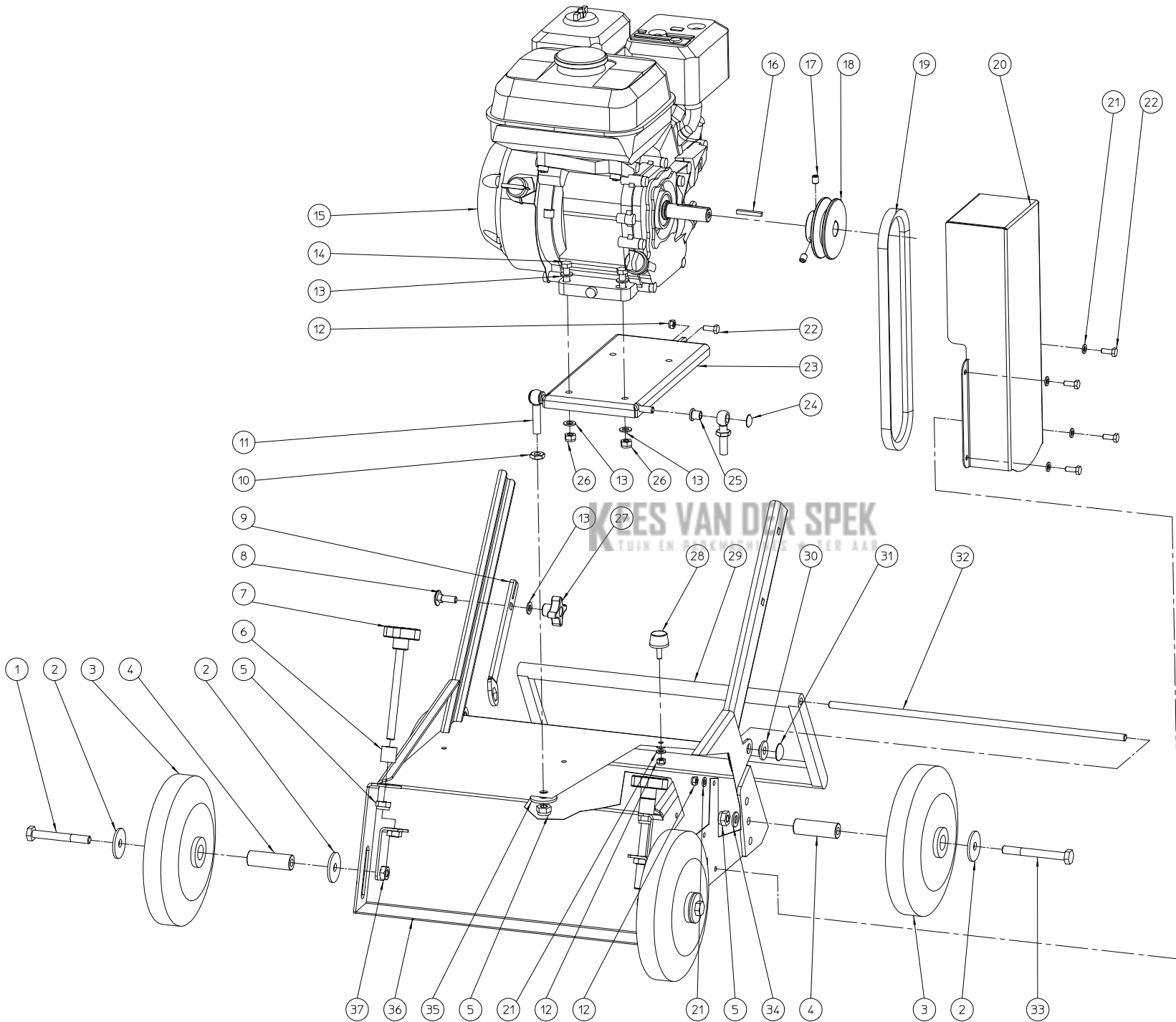

E 401 -- CHASSIS RUBBER WHEELS					
NO	MMA 01 080 221	REV	1	DATE	2016/01/25

#	Bestelnummer	Omschrijving	Aantal
1	BS 511 001 048	bout m10x80 din 931	2
2	BS 532 010 406	rondsel m10x40x3	6
3	BW 120 020 000	wiel 200/50	4
4	MPA 01 080 230	wielas nylon wiel ks - e401 vervangen door mpa 01 360 300	4
5	BS 502 001 000	borgmoer met nylonring m10 din 985	6
6	BR 111 102 010	nylon bus (10/20x20)	2
7	BN 630 210 500	sterknopschroef 189-50 m10x120	2
8	BS 554 100 825	bout m8x25 din 603	1
9	MPA 01 080 240	mesrechter + sleutel 17	1
10	BS 501 901 000	moer m10 din 439	2
11	BS 551 101 042	oogbout m10x50 din 444	2
12	BS 502 000 600	borgmoer met nylonring m6 din 985	8
13	BS 531 000 800	rondsel m8 din 125	9
14	BS 511 000 835	bout m8x35 din 931	4
15	BM 202 104 001	honda gx 120	1
16	BB 342 050 535	spie 4.7x4.7x35 din 6880	1
17	BS 023 000 810	stelschroef m8x10 din 916	2
18	BA 565 707 502	riemschijf spa 75x3/4"x3/16" (motor)	1
19	BA 521 207 490	riem xpa	1
20	MPA 01 080 170	riemkap benzinemotor	1
21	BS 531 000 600	rondsel m6 din 125	11
22	BS 512 000 616	bout m6x16 din 933	5
23	MPA 01 080 150	motorplaat benzinemotor	1
24	BB 011 000 080	starlock 8mm	2
25	BR 112 081 300	nylon bus met kraag (8/11/16x13/2)	2
26	BS 502 000 800	borgmoer met nylonring m8 din 985	4
27	BN 630 808 400	sterknopmoer 188-40 m8	1
28	BR 600 425 170	rubber trillingsdemper 25x17b m6x18	1
29	BR 900 000 500	rubber spatklep	1
30	BR 112 100 600	nylon bus met kraag (10/13.5/25x6/2.5)	2
31	BB 011 000 090	starlock 9mm	2
32	MPA 01 080 260	as 9mm rubber afscherming	1
33	BS 511 001 049	bout m10x90 din 931	2
34	BS 531 001 000	rondsel m10 din 125	2
35	BS 532 010 356	rondsel m10x35x3	2
36	MPA 01 080 100	chassis e401	1
37	MPA 01 080 220	bevestiging voorwiel	2

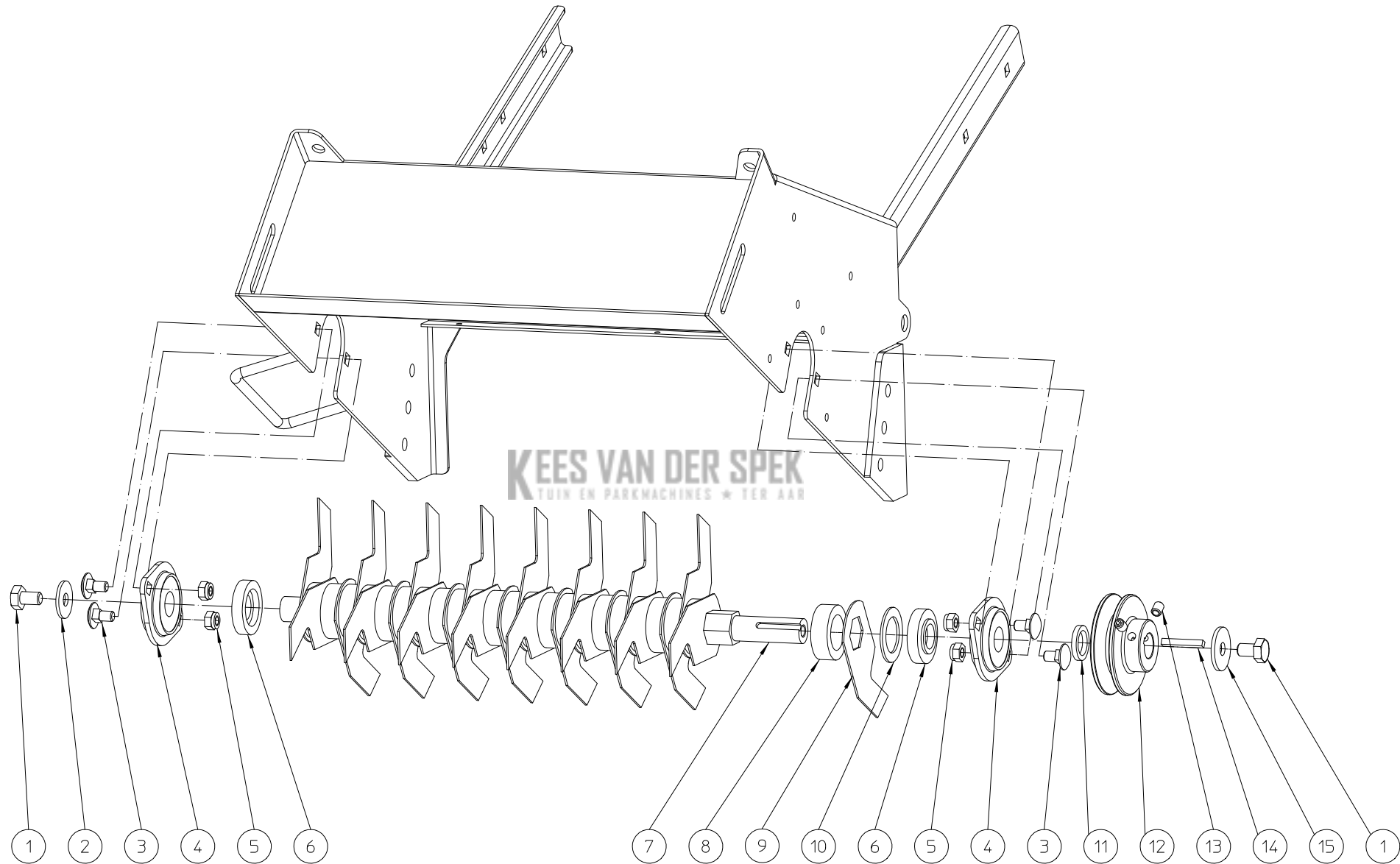

ELIET E401 -- ROTOR SHAFT ECO LINER				
NO	MMA 01 080 112	REV	1	DATE 2016/03/01

#	Bestelnummer	Omschrijving	Aantal
1	BS 512 001 016	bout m10x16 din 933	2
2	BS 532 010 305	rondsel m10x30x2.5	1
3	BS 554 100 816	bout m8x16 din 603	4
4	BL 801 102 000	lager + flenzen cspfl 204	2
5	BS 502 000 800	borgmoer met nylonring m8 din 985	4
6	MPA 01 080 510	tussenring mesas e401	2
7	MPA 01 080 500	mesas	1
8	BR 111 291 410	nylon bus (28.5/44x14)	23
9	BU 402 300 202	set vaste messen (24 ) eco liner	1
10	BS 032 029 444	rondsel 29x44x2mm	1
11	MPA 01 080 520	tussenring mesas e401	1
12	BA 565 707 503	riemschijf spa 75x20x5 (rotor)	1
13	BS 023 000 810	stelschroef m8x10 din 916	2
14	BB 341 050 535	spie 5x5x35 din 6880	1
15	BS 532 010 356	rondsel m10x35x3	1

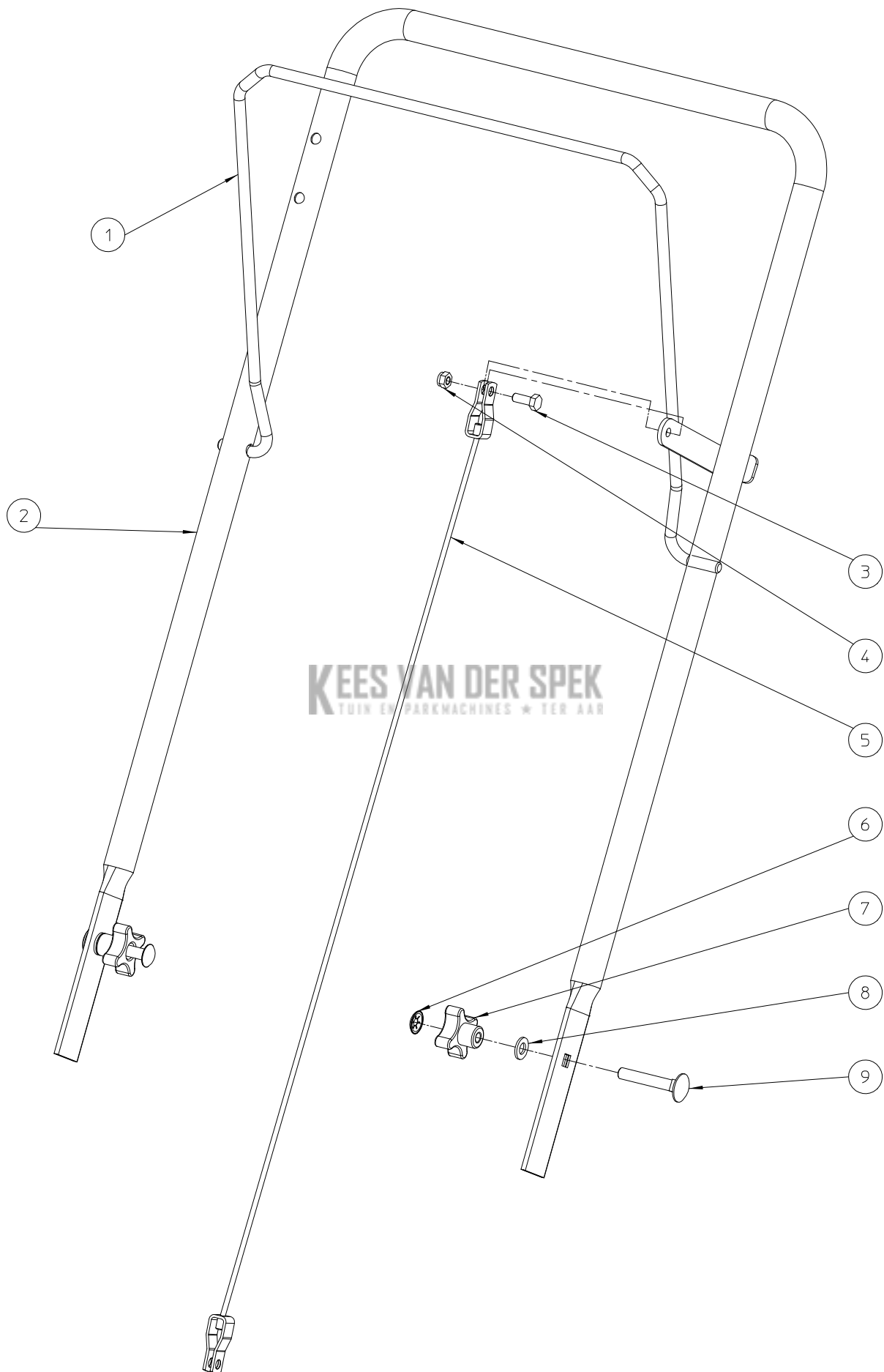

E401 -- HANDLEBAR NO RUBBER					
NO	MMA 01 080 231	REV	1	DATE	2016/03/01

#	Bestelnummer	Omschrijving	Aantal
1	MPA 01 080 135	koppelingshendel benz. motor	1
2	MPA 01 080 125	vast stuur	1
3	BS 512 000 616	bout m6x16 din 933	1
4	BS 502 000 600	borgmoer met nylonring m6 din 985	1
5	BK 152 250 730	kabel 2.5x730mm	1
6	BB 011 000 060	starlock 6mm	2
7	BN 630 808 400	sterknopmoer 188-40 m8	2
8	BS 531 000 800	rondsel m8 din 125	2
9	BS 554 100 842	bout m8x50 din 603	2