

ELIET E401 -- COMBUSTION					
NO	MMA 01 080 100	REV	2	DATE	2006/06/15

#	Bestelnummer	Omschrijving	Aantal
1	BS 502 000 800	borgmoer met nylonring m8 din 985	4
2	BS 531 000 800	rondsel m8 din 125	11
3	MPA 01 080 150	motorplaat benzinemotor	1
4	BR 112 081 300	nylon bus met kraag (8/11/16x13/2)	2
5	BS 551 101 042	oogbout m10x50 din 444	2
6	BS 501 001 000	moer m10 din 934	2
7	BB 011 000 080	starlock 8mm	2
8	BS 511 000 835	bout m8x35 din 931	4
9	MPA 01 080 200	riemvanger riemschijf motor e401	1
10	BS 512 040 816	bout unf 5/16"x5/8"	2
11	BQ 505 010 030	sticker max 3200 t/min 90x25	1
12	BM 201 003 500	motor b&s intek 3.5 pk (as 3/4")	1
13	BB 342 050 535	spie 4.7x4.7x35 din 6880	1
14	BA 565 707 502	riemschijf spa 75x3/4"x3/16" (motor)	1
15	BS 023 000 810	stelschroef m8x10 din 916	2
16	BS 554 100 825	bout m8x25 din 603	1
17	BS 554 100 842	bout m8x50 din 603	2
18	MPA 01 080 240	mesrechter + sleutel 17	1
19	BN 630 808 400	sterknopmoer 188-40 m8	3
20	BB 011 000 060	starlock 6mm	2
21	BR 600 425 170	rubber trillingsdemper 25x17b m6x18	1
22	BS 531 000 600	rondsel m6 din 125	11
23	BS 502 000 600	borgmoer met nylonring m6 din 985	9
24	BS 512 000 616	bout m6x16 din 933	8
25	MPA 01 080 110	vast stuur benzine e401	1
26	MPA 01 080 130	beugelkoppeling benzinemotor - e400 (zwart)	1
27	BK 152 250 730	kabel 2.5x730mm	1
28	MMA 01 080 140	kit opvangzak	1
29	MPA 01 080 260	as 9mm rubber afscherming	1
30	BR 112 100 600	nylon bus met kraag (10/13.5/25x6/2.5)	2
31	BB 011 000 090	starlock 9mm	2
32	BR 900 000 500	rubber spatklep	1
33	BS 502 001 000	borgmoer met nylonring m10 din 985	6
34	BS 531 001 000	rondsel m10 din 125	2
35	MPA 01 080 230	wielas nylon wiel ks - e401 vervangen door mpa 01 360 300	4
36	BS 511 001 049	bout m10x90 din 931	2
37	BS 532 010 406	rondsel m10x40x3	6
38	BW 120 020 000	wiel 200/50	4
39	MPA 01 080 190	riemvanger riemschijf mesas e401	1
40	BQ 505 010 070	veiligheidssticker 100x80 (snijwonden)	1
41	MPA 01 080 170	riemkap benzinemotor	1
42	BA 521 207 490	riem xpa	1
43	BS 511 001 048	bout m10x80 din 931	2
44	MMA 01 080 110	rotor vaste messen	1
45	BS 532 010 356	rondsel m10x35x3	2
46	BQ 505 010 050	veiligheidssticker 60x100 (pictogram)	1
47	BQ 505 010 040	veiligheidssticker 60x100 (bougie)	1
48	BQ 505 010 150	veiligheidssticker 60x100 (afstand)	1
49	BQ 505 010 010	identiteitsticker ce 120x30	0
50	BQ 501 080 010	sticker eliet e401 330x130	1
51	MPA 01 080 100	chassis e401	1
52	MPA 01 080 220	bevestiging voorwiel	2

53	BR 111 102 010	nylon bus (10/20x20)	2
54	BN 630 210 500	sterknopschroef 189-50 m10x120	2
55	BZ 201 080 010	handleiding e401	1

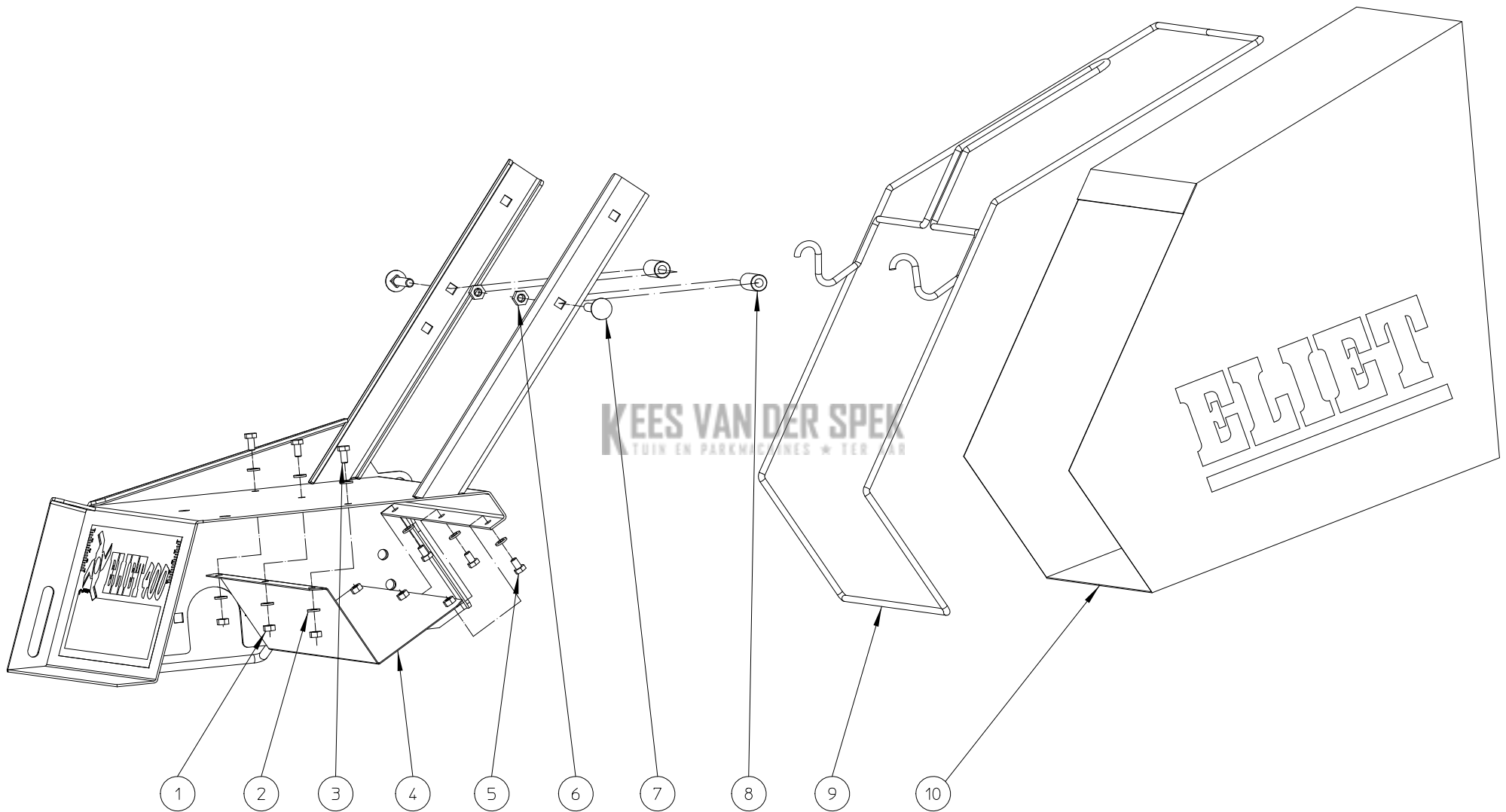

ELIET E401 -- KIT COLLECTING BAG				
NO	MMA 01 080 140	REV	1	DATE 2006/07/06

#	Bestelnummer	Omschrijving	Aantal
1	BS 501 000 600	moer m6 din 934	3
2	BS 531 000 600	rondsel m6 din 125	9
3	BS 512 000 612	bout m6x12 din 933	3
4	MPA 01 080 250	deflectorplaat e401	1
5	BS 512 000 610	bout m6x10 din 933	3
6	BS 501 000 800	moer m8 din 934	2
7	BS 554 100 842	bout m8x50 din 603	2
8	MPA 01 080 280	bus steun opvangzak	2
9	MPA 01 080 270	frame opvangzak	1
10	BQ 348 080 010	opvangzak	1

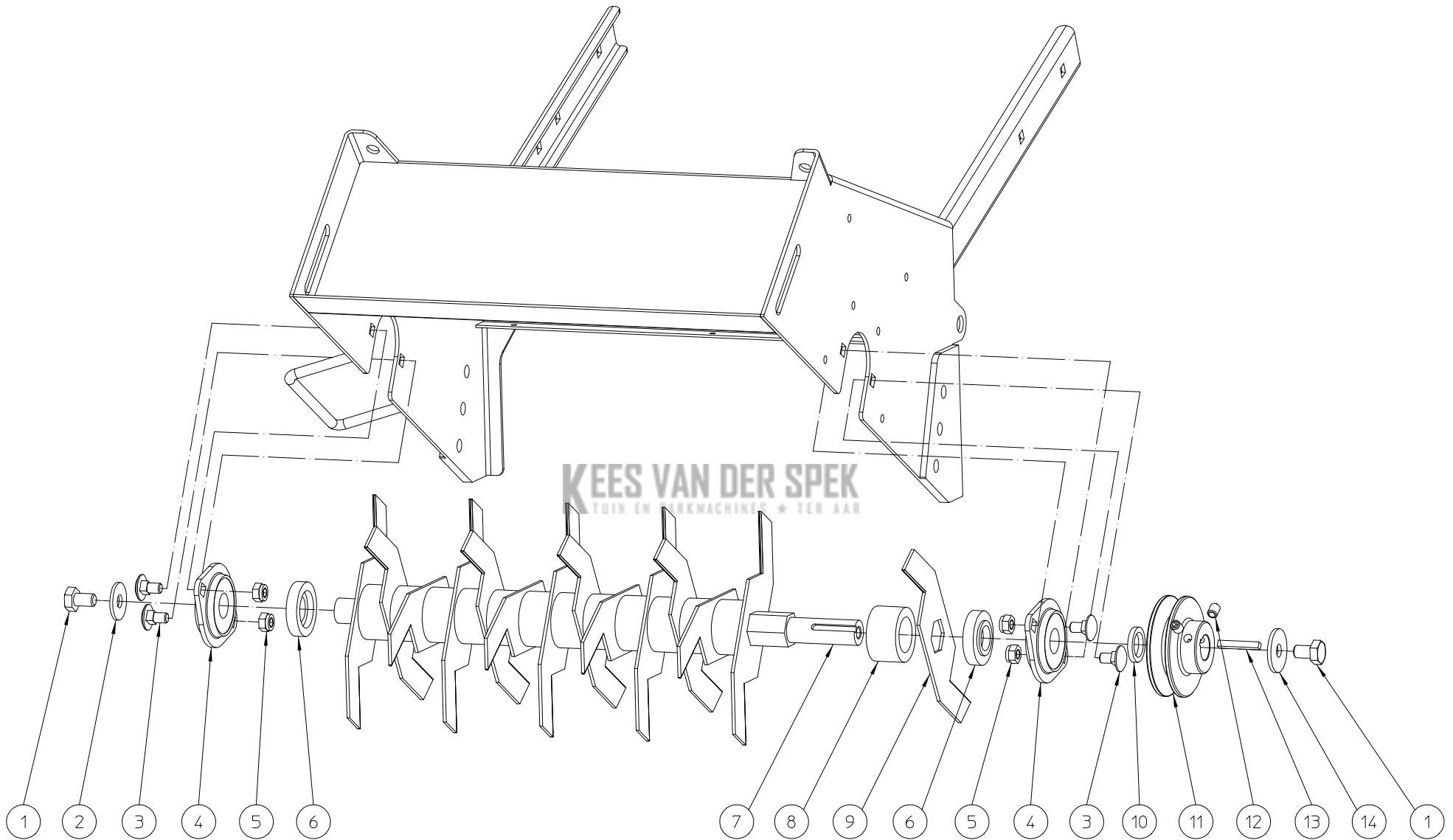

ELIET E401 -- ROTOR SHAFT FIXED KNIVES

NO	MMA 01 080 110	REV	1	DATE	2014/01/24
----	----------------	-----	---	------	------------

#	Bestelnummer	Omschrijving	Aantal
1	BS 512 001 016	bout m10x16 din 933	2
2	BS 532 010 305	rondsel m10x30x2.5	1
3	BS 554 100 816	bout m8x16 din 603	4
4	BL 801 102 000	lager + flenzen cspfl 204	2
5	BS 502 000 800	borgmoer met nylonring m8 din 985	4
6	MPA 01 080 510	tussenring mesas e401	2
7	MPA 01 080 500	mesas	1
8	BR 111 292 510	nylon bus (28.5/44x25)	13
9	BU 402 100 101	set vaste messen (14)	1
10	MPA 01 080 520	tussenring mesas e401	1
11	BA 565 707 503	riemschijf spa 75x20x5 (rotor)	1
12	BS 023 000 810	stelschroef m8x10 din 916	2
13	BB 341 050 535	spie 5x5x35 din 6880	1
14	BS 532 010 356	rondsel m10x35x3	1