

KES VAN DER SPEK
TUIN- EN GRASMAASJNEN

ELIET E501					
NO	MMA-01.090.100	REV	1	DATE	2009/10/14

#	Bestelnummer	Omschrijving	#
1	BM 202 005 500	HONDA GC 160	1
2	MPA 01 090 150	RIEMVANGER	1
3	BQ 505 010 030	STICKER MAX 3200 T/MIN 90X25	1
4	BS 023 000 810	STELSCHROEF M8X10 DIN 916	2
5	BA 565 707 101	RIEMSCHIJF SPA 71X3/4"X3/16" (MOTOR)	1
6	BS 512 040 816	BOUT UNF 5/16"X5/8"	2
7	BS 505 500 600	MOER M6 DIN 1587	4
8	BS 531 000 600	RONDSEL M6 DIN 125	17
9	BS 511 000 635	BOUT M6X35 DIN 931	4
10	BB 001 000 100	BORGRING 10 DIN 471	4
11	BR 111 102 000	NYLON BUS (10.3/15x20)	1
12	BR 112 101 500	NYLON BUS MET KRAAG (10/13/18x15/2)	4
13	MPA 01 090 210	HEFBOOM RIEMONTKOPPELING	1
14	MPA 01 090 180	ONDERSTE STUURBEUGEL	1
15	MPA 01 090 170	BOVENSTE STUURBEUGEL	1
16	MPA 01 090 280	ONTKOPPELINGSHENDEL	1
17	BV 909 000 040	ONTKOPPELINGSSTANG	1
18	BY 512 032 344	KETTING	1
19	MPA 01 090 220	KETTING BEVESTIGING	1
20	BR 111 101 500	NYLON BUS (10.3/15x15)	1
21	BR 900 000 510	RUBBER ANTI-PROJECTIE SCHILD	1
22	MPA 01 090 230	AS	1
23	BR 112 100 600	NYLON BUS MET KRAAG (10/13.5/25x6/2.5)	2
24	BB 011 000 090	STARLOCK 9MM	2
25	BS 522 500 616	SCHROEF M6X16 ISO 7380	1
26	MPA 01 090 130	AANSLAG	1
27	BS 502 000 600	BORGMOER MET NYLONRING M6 DIN 985	5
28	BS 512 000 616	BOUT M6X16 DIN 933	4
29	BQ 505 010 070	VEILIGHEIDSSTICKER 100X80 (SNIJWONDEN)	1
30	MPA 01 090 250	AFSCHERMING AANDRIJVING	1
31	BA 521 208 000	RIEM XPA 800	1
32	BS 511 001 251	BOUT M12X110 DIN 931	2
33	BS 532 012 456	RONDSEL M12X45X3	2
34	BW 125 020 000	ACHTERWIEL 250/60-130 (E 501)	2
35	MPA 01 090 310	AS ACHTERWIEL 75MM (E 501)	2
36	MPA 01 090 290	ACHTERWIELSCHRAPER	2
37	BS 531 001 200	RONDSEL M12 DIN 125	2
38	BS 502 001 200	BORGMOER MET NYLONRING M12 DIN 985	4
39	BS 512 001 016	BOUT M10X16 DIN 933	2
40	BS 532 010 406	RONDSEL M10X40X3	2
41	BW 120 020 000	WIEL 200/50	2
42	MPA 01 090 270	VOORWIELHOUDER RECHTS	1
43	MPA 01 090 100	AS VOORWIEL	1
44			
45	MPA 01 090 120	CHASSIS	1
46	BQ 505 010 150	VEILIGHEIDSSTICKER 60X100 (AFSTAND)	1
47	BQ 501 090 010	STICKER ELIET E 501 364X122	1
48	BQ 505 010 040	VEILIGHEIDSSTICKER 60X100 (BOUGIE)	1
49	BQ 505 010 050	VEILIGHEIDSSTICKER 60X100 (PICTOGRAM)	1
50	MPA 01 090 110	VOORWIELHOUDER LINKS	1
51	BS 502 001 400	BORGMOER MET NYLONRING M14 DIN 985	4

52	BS 531 001 000	RONDSEL M10 DIN 125	1
53	BB 040 102 040	BETASPELD 2MM DIN 11024	1
54	MPA 01 090 260	VERGRENDELHENDEL	2
55	BV 909 000 030	VEER	2
56	BN 630 214 600	STERKNOPSCHROEF 189-60 M14X135	2
57	BS 502 000 800	BORGMOER MET NYLONRING M8 DIN 985	4
58	BS 531 000 800	RONDSEL M8 DIN 125	8
59	BQ 505 010 010	IDENTITEITSTICKER CE 120X30	0
60	MPA 01 090 140	MOTORPLAAT	1
61	BS 551 101 242	OOGBOUW M12X50 DIN 444	2
62	BS 501 901 200	MOER M12 DIN 439	2
63	BB 011 000 100	STARLOCK 10MM	2
64	BS 522 500 835	SCHROEF M8X35 ISO 7380	2
65	BS 511 000 835	BOUT M8X35 DIN 931	2
66	BB 342 050 535	SPIE 4.7X4.7X35 DIN 6880	1
67	BZ 201 090 010	HANDLEIDING E501	1

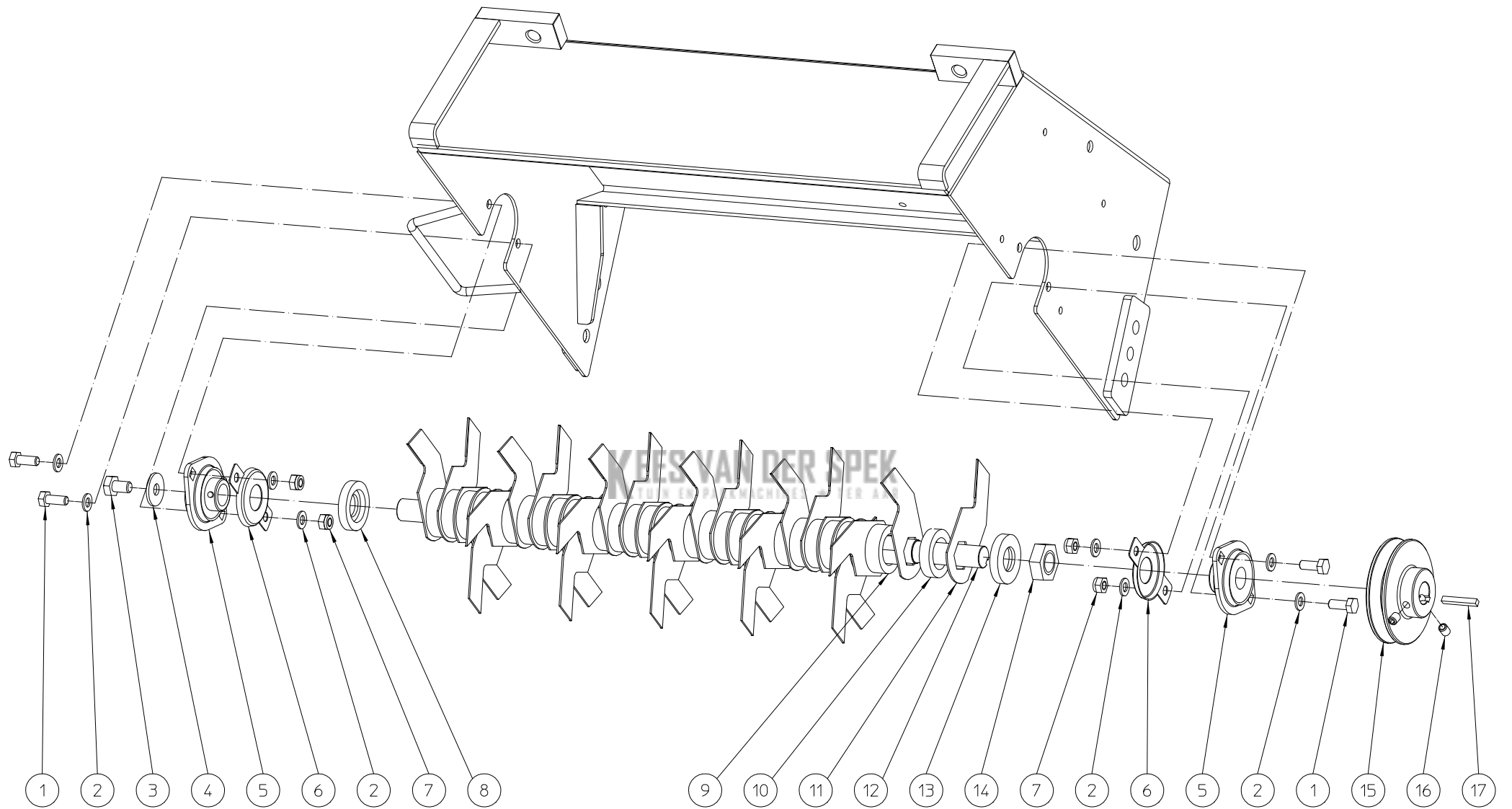

ELIET E501 --- ROTOR SHAFT DOUBLE CUT KNIVES				
NO	MMA-01.090.130	REV	1	DATE 2006/07/06

#	Bestelnummer	Omschrijving	#
1	BS 512 000 820	BOUT M8X20 DIN 933	4
2	BS 531 000 800	RONDSEL M8 DIN 125	8
3	BS 512 001 016	BOUT M10X16 DIN 933	1
4	BS 532 010 305	RONDSEL M10X30X2.5	1
5	BL 801 102 001	LAGER + FLENZEN ASPFL 204	2
6	MPA 01 010 010	LAGERAFSCHERMING 204	2
7	BS 502 000 800	BORGMOER MET NYLONRING M8 DIN 985	4
8	MPA 01 090 520	MESVLOOT 20X45X8MM	1
9	BR 111 291 410	NYLON BUS (28.5/44x14)	30
10	BR 111 291 010	NYLON BUS (28.5/44x10)	1
11	BU 402 300 102	SET MESSEN DOUBLE CUT (32)	1
12	MPA 01 090 500	MESAS	1
13	MPA 01 090 510	MESVLOOT 22X45X8MM	1
14	BS 501 902 200	MOER M22X1.50 DIN 439	1
15	BA 565 709 001	RIEMSCHIJF SPA 90X20X5 (ROTOR)	1
16	BS 023 000 810	STELSCHROEF M8X10 DIN 916	2
17	BB 341 050 535	SPIE 5X5X35 DIN 6880	1

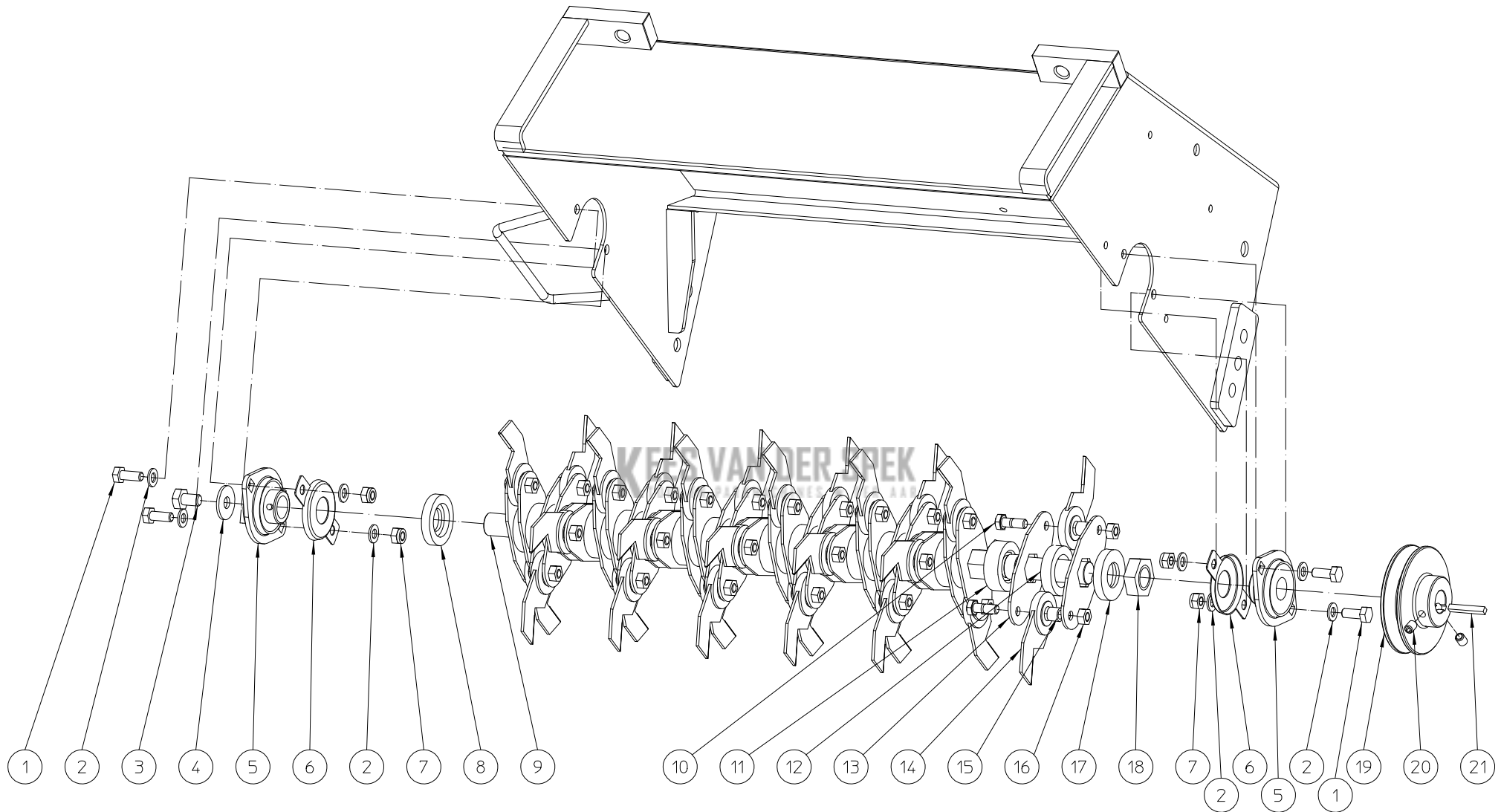

ELIET E501 --- ROTOR SHAFT LOOSE KNIVES

NO	MMA-01.090.120	REV	1	DATE	2006/07/06
----	-----------------------	-----	---	------	------------

#	Bestelnummer	Omschrijving	#
1	BS 512 000 820	BOUT M8X20 DIN 933	4
2	BS 531 000 800	RONDSEL M8 DIN 125	8
3	BS 512 001 016	BOUT M10X16 DIN 933	1
4	BS 532 010 305	RONDSEL M10X30X2.5	1
5	BL 801 102 001	LAGER + FLENZEN ASPFL 204	2
6	MPA 01 010 010	LAGERAFSCHERMING 204	2
7	BS 502 000 800	BORGMOER MET NYLONRING M8 DIN 985	4
8	MPA 01 090 520	MESVLOOT 20X45X8MM	1
9	MPA 01 090 500	MESAS	1
10	BS 011 000 822	BOUT M8X22 DIN 931	34
11	BR 111 291 410	NYLON BUS (28.5/44x14)	16
12	BR 111 291 010	NYLON BUS (28.5/44x10)	17
13	MPA 01 090 530	MESHOUDER LOS MES	34
14	BU 402 200 102	SET LOSSE MESSEN MET BUS (34)	1
15	MPA 01 090 540	BUS LOS MES	0
16	BS 501 000 800	MOER M8 DIN 934	34
17	MPA 01 090 510	MESVLOOT 22X45X8MM	1
18	BS 501 902 200	MOER M22X1.50 DIN 439	1
19	BA 565 709 001	RIEMSCHIJF SPA 90X20X5 (ROTOR)	1
20	BS 023 000 810	STELSCHROEF M8X10 DIN 916	2
21	BB 341 050 535	SPIE 5X5X35 DIN 6880	1

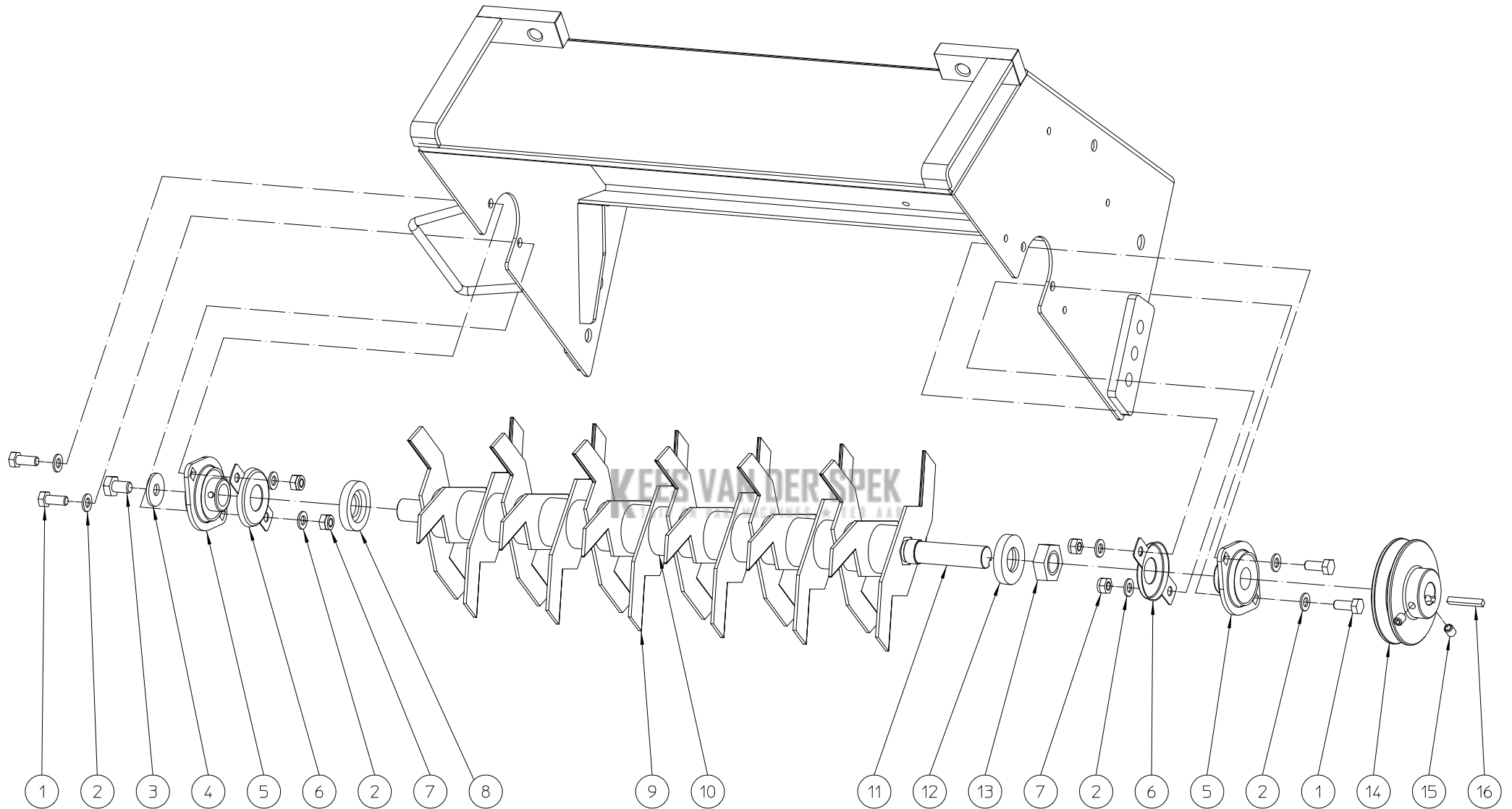

ELIET E501 -- ROTOR SHAFT FIXED KNIVES				
NO	MMA-01.090.110	REV	1	DATE 2006/07/06

#	Bestelnummer	Omschrijving	#
1	BS 512 000 820	BOUT M8X20 DIN 933	4
2	BS 531 000 800	RONDSEL M8 DIN 125	8
3	BS 512 001 016	BOUT M10X16 DIN 933	1
4	BS 532 010 305	RONDSEL M10X30X2.5	1
5	BL 801 102 001	LAGER + FLENZEN ASPFL 204	2
6	MPA 01 010 010	LAGERAFSCHERMING 204	2
7	BS 502 000 800	BORGMOER MET NYLONRING M8 DIN 985	4
8	MPA 01 090 520	MESVLOOT 20X45X8MM	1
9	BU 402 100 201	SET VASTE MESSEN (18)	1
10	BR 111 292 510	NYLON BUS (28.5/44x25)	17
11	MPA 01 090 500	MESAS	1
12	MPA 01 090 510	MESVLOOT 22X45X8MM	1
13	BS 501 902 200	MOER M22X1.50 DIN 439	1
14	BA 565 709 001	RIEMSCHIJF SPA 90X20X5 (ROTOR)	1
15	BS 023 000 810	STELSCHROEF M8X10 DIN 916	2
16	BB 341 050 535	SPIE 5X5X35 DIN 6880	1